

---

Stream: Internet Engineering Task Force (IETF)  
RFC: [9944](#)  
Category: Standards Track  
Published: March 2026  
ISSN: 2070-1721  
Authors:  
M. Shahzad H. Iqbal E. Lear  
*North Carolina State University North Carolina State University Cisco Systems*

# RFC 9944

## Device Schema Extensions to the System for Cross-Domain Identity Management (SCIM) Model

---

### Abstract

The initial core schema for the System for Cross-domain Identity Management (SCIM) was designed for provisioning users. This memo specifies schema extensions that enable provisioning of devices using various underlying bootstrapping systems such as Wi-Fi Easy Connect, FIDO device onboarding vouchers, Bluetooth Low Energy (BLE) passcodes, and MAC Authenticated Bypass (MAB).

### Status of This Memo

This is an Internet Standards Track document.

This document is a product of the Internet Engineering Task Force (IETF). It represents the consensus of the IETF community. It has received public review and has been approved for publication by the Internet Engineering Steering Group (IESG). Further information on Internet Standards is available in Section 2 of RFC 7841.

Information about the current status of this document, any errata, and how to provide feedback on it may be obtained at <https://www.rfc-editor.org/info/rfc9944>.

### Copyright Notice

Copyright (c) 2026 IETF Trust and the persons identified as the document authors. All rights reserved.

This document is subject to BCP 78 and the IETF Trust's Legal Provisions Relating to IETF Documents (<https://trustee.ietf.org/license-info>) in effect on the date of publication of this document. Please review these documents carefully, as they describe your rights and restrictions

with respect to this document. Code Components extracted from this document must include Revised BSD License text as described in Section 4.e of the Trust Legal Provisions and are provided without warranty as described in the Revised BSD License.

## Table of Contents

1. Introduction	4
1.1. Why SCIM for Devices?	5
1.2. Protocol Participants	5
1.3. Schema Description	7
1.4. Schema Representation	7
1.5. Terminology	8
2. ResourceType Device	8
2.1. Common Attributes	8
3. SCIM Core Device Schema	8
3.1. Singular Attributes	8
4. Groups	10
5. Resource Type EndpointApp	10
6. SCIM EndpointApp Schema	10
6.1. Common Attributes	10
6.2. Singular Attributes	10
6.3. Complex Attributes	11
6.3.1. certificateInfo	11
7. SCIM Device Extensions	12
7.1. Bluetooth Low Energy (BLE) Extension	12
7.1.1. Singular Attributes	13
7.1.2. Multivalued Attributes	13
7.1.3. BLE Pairing Method Extensions	14
7.2. Wi-Fi Easy Connect Extension	18
7.2.1. Singular Attributes	18
7.2.2. Multivalued Attributes	19

---

7.3. Ethernet MAB Extension	20
7.3.1. Single Attribute	20
7.4. FIDO Device Onboard Extension	21
7.4.1. Single Attribute	21
7.5. Zigbee Extension	22
7.5.1. Singular Attribute	22
7.5.2. Multivalued Attribute	23
7.6. The Endpoint Applications Extension Schema	23
7.6.1. Singular Attributes	24
7.6.2. Multivalued Attribute	24
8. Security Considerations	27
8.1. SCIM Operations	27
8.1.1. Unauthorized Object Creation	27
8.2. Object Deletion	27
8.3. Read Operations	27
8.4. Update Operations	27
8.5. Higher Level Protection for Certain Systems	28
8.6. Logging	28
9. IANA Considerations	28
9.1. New Schemas	28
9.2. Device Schema Extensions	28
10. References	29
10.1. Normative References	29
10.2. Informative References	30
Appendix A. JSON Schema Representation	32
A.1. Resource Schema	32
A.2. Core Device Schema	32
A.3. EndpointApp Schema	34
A.4. BLE Extension Schema	37

---

A.5. DPP Extension Schema	41
A.6. Ethernet MAB Extension Schema	43
A.7. FDO Extension Schema	44
A.8. Zigbee Extension Schema	45
A.9. endpointAppsExt Extension Schema	45
Appendix B. OpenAPI Representation	47
B.1. Core Device Schema OpenAPI Representation	47
B.2. EndpointApp Schema OpenAPI Representation	49
B.3. BLE Extension Schema OpenAPI Representation	52
B.4. DPP Extension Schema OpenAPI Representation	55
B.5. Ethernet MAB Extension Schema OpenAPI Representation	56
B.6. FDO Extension Schema OpenAPI Representation	57
B.7. Zigbee Extension Schema OpenAPI Representation	58
B.8. endpointAppsExt Extension Schema OpenAPI Representation	59
Appendix C. FIDO Device Onboarding Example Flow	61
Acknowledgments	63
Authors' Addresses	63

## 1. Introduction

The Internet of Things presents a management challenge in many dimensions. One of them is the ability to onboard and manage a large number of devices. There are many models for bootstrapping trust between devices and network deployments. Indeed, it is expected that different manufacturers will make use of different methods.

The System for Cross-domain Identity Management (SCIM) [RFC7643] [RFC7644] defines a protocol and a schema for the provisioning of users. However, it can easily be extended to provision device credentials and other attributes into a network. The protocol and core schema were designed to permit just such extensions. Bulk operations are supported. This is good because often devices are procured in bulk.

A primary purpose of this specification is to provision the network for onboarding and communications access to and from devices within a local deployment based on the underlying capabilities of those devices.

The underlying security mechanisms of some devices range from non-existent such as the Bluetooth Low Energy (BLE) "Just Works" pairing method to a robust FIDO Device Onboard (FDO) mechanism. Information from the SCIM server is dispatched to control functions based on selected schema extensions to enable these communications within a network. The SCIM database is therefore essentially equivalent to a network's Authentication, Authorization, and Accounting (AAA) database and should be carefully managed as such.

### 1.1. Why SCIM for Devices?

There are a number of existing models that might provide the basis for a scheme for provisioning devices onto a network, including two standardized by the IETF: NETCONF [RFC6241] or RESTCONF [RFC8040] with YANG [RFC7950]. SCIM was chosen for the following reasons:

- NETCONF and RESTCONF focus on **configuration** rather than provisioning.
- SCIM is designed with inter-domain provisioning in mind. The use of HTTP as a substrate permits both user-based authentication for local provisioning applications, as well as OAUTH or certificate-based authentication. The inter-domain nature of these operations does not expose local policy, which itself must be (and often is) configured with other APIs, many of which are not standardized.
- SCIM is also a familiar tool within the enterprise environment, used extensively to configure federated user accounts.
- Finally, once one chooses a vehicle such as SCIM, one is beholden to its data model. The SCIM data model is more targeted to provisioning as articulated in [RFC7643].

This taken together with the fact that end devices are not intended to be **directly** configured leaves us with SCIM as the best standard option.

### 1.2. Protocol Participants

In the normal SCIM model, it was presumed that large federated deployments would be SCIM clients who provision and remove employees and contractors as they enter and depart those deployments, and federated services such as sales, payment, or conferencing services would be the servers.

In the device model, the roles are reversed and may be somewhat more varied. The SCIM server resides within a deployment and is used for receiving information about devices that are expected to be connected to its network. That server will apply appropriate local policies regarding whether/how the device should be connected.

The client may be one of a number of entities:

- A vendor who is authorized to add devices to a network as part of a sales transaction. This is similar to the sales integration sometimes envisioned by Bootstrapping Remote Secure Key Infrastructure (BRSKI) [RFC8995].

- A client application that administrators or employees use to add, remove, or get information about devices. An example might be a tablet or phone app that scans Wi-Fi Easy Connect QR codes.

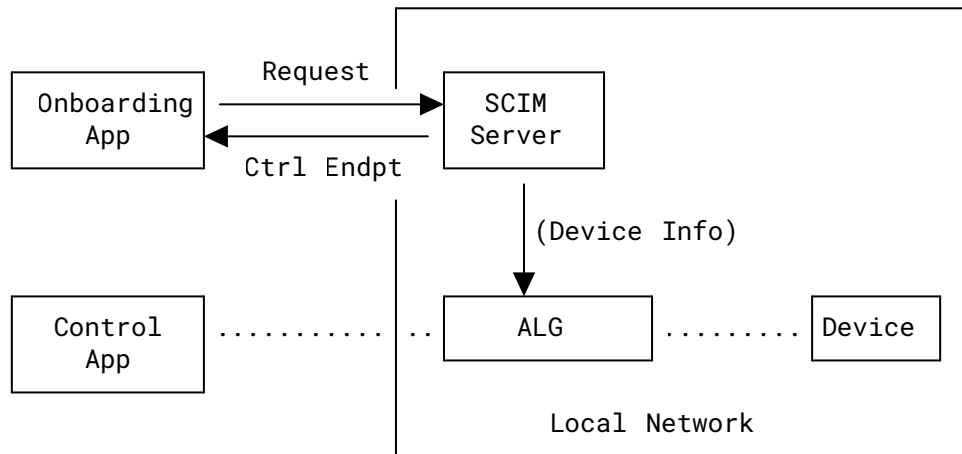

Figure 1: Basic Architecture - Non-IP Example

In [Figure 1](#), the onboarding application (app) provides the device particulars, which will vary based on the type of device, as indicated by the selection of schema extensions. As part of the response, the SCIM server might provide additional information, especially in the case of non-IP devices, where an application-layer gateway may need to be used to communicate with the device (c.f., [NIPC](#)). The control endpoint is one among a number of objects that may be returned. That control endpoint will then communicate with the Application Layer Gateway (ALG) to reach the device.

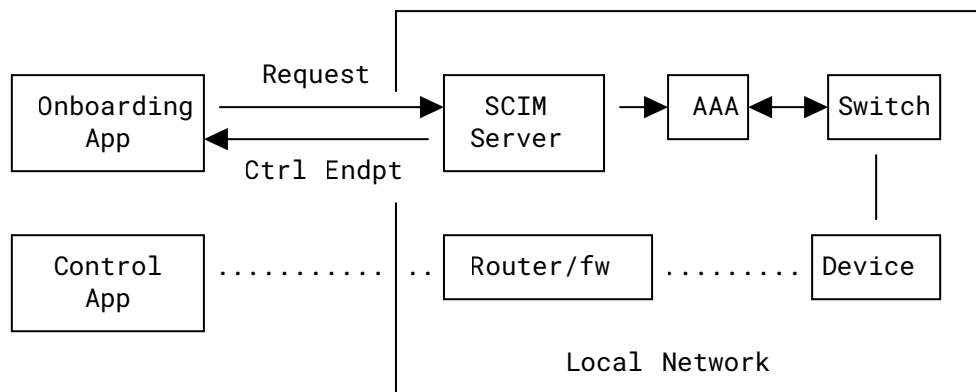

Figure 2: Interaction with AAA

Figure 2 shows how IP-based endpoints can be provisioned. In this case, the onboarding application provisions a device via SCIM. The necessary information is passed to the Authentication, Authorization, and Accounting (AAA) subsystem, such that the device is permitted to connect. Once it is online, since the device is based on IP, it will not need an ALG, but it will use the normal IP infrastructure to communicate with its control application.

### 1.3. Schema Description

[RFC7643] does not prescribe a language to describe a schema but instead uses a narrative description with examples. We follow that approach. In addition, we provide non-normative JSON Schemas [JSONSchema] and OpenAPI [OpenAPI] versions in the appendices for ease of implementation, neither of which existed when SCIM was originally developed. The only difference the authors note between the normative schema representations is that the JSON Schemas and OpenAPI versions do not have a means to express case sensitivity, and thus attributes that are not case sensitive must be manually validated.

Several additional schemas specify specific onboarding mechanisms, such as Bluetooth Low Energy (BLE) [BLE54], Wi-Fi Easy Connect [DPP2], and FIDO Device Onboard [FDO11].

When JSON is presented in this memo, it is folded in accordance with [RFC8792].

### 1.4. Schema Representation

Attributes defined in the device core schema (see Section 2.2 of [RFC7643]) and extensions comprise characteristics and the SCIM datatypes (defined in Section 2.3 of [RFC7643]). This specification does not define new characteristics and datatypes for the SCIM attributes.

## 1.5. Terminology

The key words "MUST", "MUST NOT", "REQUIRED", "SHALL", "SHALL NOT", "SHOULD", "SHOULD NOT", "RECOMMENDED", "NOT RECOMMENDED", "MAY", and "OPTIONAL" in this document are to be interpreted as described in BCP 14 [RFC2119] [RFC8174] when, and only when, they appear in all capitals, as shown here.

The reader is also expected to be familiar with the narrative schema language used in [RFC7643].

## 2. ResourceType Device

A new resource type Device is specified. The "ResourceType" schema specifies the metadata about a resource type (see Section 6 of [RFC7643]). It comprises a core device schema and several extension schemas. This schema provides a minimal resource representation, whereas extension schemas extend it depending on the device's capability.

### 2.1. Common Attributes

The device schema contains three common attributes as defined in Section 3.1 of [RFC7643]. No semantic or syntax changes are made here, but the attributes are listed merely for completeness.

**id:** A required and unique attribute of the core device schema (see Section 3.1 of [RFC7643]).

**externalId:** An optional attribute (see Section 3.1 of [RFC7643]).

**meta:** A required and complex attribute (see Section 3.1 of [RFC7643]).

## 3. SCIM Core Device Schema

The core device schema provides the minimal representation of a resource Device. It contains only those attributes that any device may need, and only one attribute is required. It is identified using the schema URI:

urn:ietf:params:scim:schemas:core:2.0:Device

The following attributes are defined in the core device schema.

### 3.1. Singular Attributes

**displayName:** A string that provides a human-readable name for a device. It is intended to be displayed to end users and should be suitable for that purpose. The attribute is not required and is not case sensitive. It may be modified and **SHOULD** be returned by default. No uniqueness constraints are imposed on this attribute.

**active:** A mutable boolean that is required. If set to true, it means that this device is intended to be operational. Attempts to control or access a device where this value is set to false may fail. For example, when used in conjunction with Non-Internet-Connected Physical Components (NIPC) [NIPC], commands (such as connect, disconnect, and subscribe) that control application sends to the controller for devices will be rejected by the controller.

**mudUrl:** A string that represents the URL to the Manufacturer Usage Description (MUD) file associated with this device. This attribute is optional, mutable, and returned by default. When present, this attribute may be used as described in [RFC8520]. The mudUrl value is case sensitive and not unique.

**groups:** An optional read-only complex object that indicates group membership. Its form is precisely the same as that defined in Section 4.1.2 of [RFC7643].

Attribute	Multi Value	Req	Case Exact	Mutable	Return	Unique
displayName	F	F	F	RW	Def	None
active	F	T	F	RW	Def	None
mudUrl	F	F	T	RW	Def	None
groups	T	F	T	RO	Def	n/a

Table 1: Characteristics of Device Schema Attributes

Legend: Req = Required, T = True, F = False, RO = ReadOnly, RW = ReadWrite, Def = Default

Example:

```
<CODE BEGINS>
{
  "schemas": ["urn:ietf:params:scim:schemas:core:2.0:Device"],
  "id": "e9e30dba-f08f-4109-8486-d5c6a3316111",
  "displayName": "BLE Heart Monitor",
  "active": true,
  "meta": {
    "resourceType": "Device",
    "created": "2022-01-23T04:56:22Z",
    "lastModified": "2022-05-13T04:42:34Z",
    "version": "W\/\\"a330bc54f0671c9\"",
    "location": "https://example.com/v2/Devices/e9e30dba-f08f-\
4109-8486-d5c6a3316111"
  }
}
<CODE ENDS>
```

Figure 3: Core Device Example Entries

## 4. Groups

Device and EndpointApp groups are created using the SCIM groups as defined in [Section 4.2](#) of [\[RFC7643\]](#). If set, the "type" subattribute of the "members" attribute **MUST** be set to Device for devices and EndpointApp for endpoint applications.

## 5. Resource Type EndpointApp

This section defines the EndpointApp resource type. The "ResourceType" schema specifies the metadata about a resource type (see [Section 6](#) of [\[RFC7643\]](#)). The resource EndpointApp represents client applications that can control and/or receive data from the devices.

## 6. SCIM EndpointApp Schema

The EndpointApp schema is used to authorize control or telemetry services for clients. The schema identifies the application and how clients are to authenticate to the various services.

The schema for EndpointApp is identified using the schema URI:

```
urn:ietf:params:scim:schemas:core:2.0:EndpointApp
```

The following attributes are defined in this schema.

### 6.1. Common Attributes

Like [Section 2.1](#), the EndpointApp schema contains the three common attributes specified in [Section 3.1](#) of [\[RFC7643\]](#).

### 6.2. Singular Attributes

**applicationType:** A string that represents the type of application. It will only contain two values: deviceControl or telemetry. deviceControl is the application that sends commands to control the device. telemetry is the application that receives data from the device. The attribute is required and is not case sensitive. The attribute is readOnly and should be returned by default. No uniqueness constraints are imposed on this attribute.

**applicationName:** A string that represents a human-readable name for the application. This attribute is required and mutable. The attribute should be returned by default and there is no uniqueness constraint on the attribute.

**clientToken:** A string that contains a token that the client will use to authenticate itself. Each token may be a string up to 500 characters in length. It is not mutable. It is read only, case sensitive, and generated if no certificateInfo object is provisioned. It is returned by default if it exists. The SCIM server should expect that client tokens will be shared by the SCIM client with other components within the client's infrastructure.

groups: An optional read-only complex object that indicates group membership. Its form is precisely the same as that defined in [Section 4.1.2](#) of [\[RFC7643\]](#).

### 6.3. Complex Attributes

#### 6.3.1. certificateInfo

certificateInfo is a complex attribute that contains an X.509 certificate's subject name and root Certificate Authority (CA) information associated with application clients that will connect for purposes of device control or telemetry.

rootCA: A base64-encoded string as described in [Section 4](#) of [\[RFC4648\]](#). It is a trust anchor certificate applicable for certificates used for client application access. The object is not required. It is singular, case sensitive, and read/write. If not present, a set of trust anchors **MUST** be configured out of band.

subjectName: When present, a string that contains one of two names:

- a distinguished name that will be present in the certificate subject field, as described in [Section 4.1.2.4](#) of [\[RFC5280\]](#) or
- a dnsName as part of a subjectAlternateName, as described in [Section 4.2.1.6](#) of [\[RFC5280\]](#).

In the latter case, servers validating such certificates **SHALL** reject connections when the name of the peer as resolved by a DNS reverse lookup does not match the dnsName in the certificate. If multiple dnsNames are present, it is left to server implementations to address any authorization conflicts associated with those names. This attribute is not required and not case sensitive. It is mutable and singular.

Attribute	Multi Value	Req	Case Exact	Mutable	Return	Unique
applicationType	F	T	F	R	Def	None
applicationName	F	T	F	RW	Def	None
clientToken	F	F	T	R	N	None
certificateInfo	F	F	F	RW	Def	None
rootCA	F	F	T	RW	Def	None
subjectName	F	T	T	RW	Def	None

Table 2: Characteristics of EndpointApp Schema Attributes

Legend: Req = Required, T = True, F = False, RO = ReadOnly, RW = ReadWrite, N = No, Def = Default

If `certificateInfo` is provided by the client and is accepted by the server, the server **MUST** return that multivalued attribute in its response. Otherwise, the server is expected to return a `clientToken`. If the server returns neither `certificateInfo` nor a `clientToken`, then external authentication such as [OAUTHv2] **MUST** be pre-arranged. If the server accepts a certificate and produces a `clientToken`, then control and telemetry servers **MUST** validate both.

`certificateInfo` is preferred in situations where client functions are federated such that different clients may connect for different purposes.

Example:

```
<CODE BEGINS>
{
  "schemas": ["urn:ietf:params:scim:schemas:core:2.0:EndpointApp"],
  "id": "e9e30dba-f08f-4109-8486-d5c6a3316212",
  "applicationType": "deviceControl",
  "applicationName": "Device Control App 1",
  "certificateInfo": {
    "rootCA": "MIIBIjAN...",
    "subjectName": "www.example.com"
  },
  "meta": {
    "resourceType": "EndpointApp",
    "created": "2022-01-23T04:56:22Z",
    "lastModified": "2022-05-13T04:42:34Z",
    "version": "W\\/\\"a330bc54f0671c9\"",
    "location": "https://example.com/v2/EndpointApps/e9e30dba-f08f-\
4109-8486-d5c6a3316212"
  }
}
<CODE ENDS>
```

Figure 4: Endpoint App Example

## 7. SCIM Device Extensions

SCIM provides various extension schemas and their attributes, along with JSON representations and example objects. The core schema is extended with a new resource type, `Device`. No `schemaExtensions` list is specified in that definition. Instead, IANA registry entries have been created, where all values for "required" are set to false. All extensions to the device schema **MUST** be registered via IANA, as described in Section 9.2. The schemas below demonstrate how this model is to work. All the SCIM server-related schema URIs are valid only with `Device` resource types.

### 7.1. Bluetooth Low Energy (BLE) Extension

This schema extends the device schema to represent the devices supporting BLE. The extension is identified using the following schema URI:

```
urn:ietf:params:scim:schemas:extension:ble:2.0:Device
```

The attributes are as follows.

### 7.1.1. Singular Attributes

**deviceMacAddress:** A string value that represents a public MAC address assigned by the manufacturer. It is a unique 48-bit value. It is required, case insensitive, mutable, and returned by default. The ECMA regular expression pattern [ECMA] is the following:

```
^[0-9A-Fa-f]{2}(:[0-9A-Fa-f]{2}){5}$
```

**isRandom:** A boolean flag. If false, the device is using a public MAC address. If true, the device uses a random address. If an Identifying Resolving Key (IRK) is present, the address represents a resolvable private address. Otherwise, the address is assumed to be a random static address. Non-resolvable private addresses are not supported by this specification. This attribute is not required. It is mutable and is returned by default. The default value is false. See Volume 6, Part B, Section 1.3 of [BLE54] for more information about different address types.

**separateBroadcastAddress:** When present, this string represents an address used for broadcasts/advertisements. This value **MUST NOT** be set when an IRK is provided. Its form is the same as deviceMacAddress. It is not required. It is multivalued, mutable, and returned by default.

**irk:** A string value that specifies the IRK, which is unique to each device. It is used to resolve a private random address. It should only be provisioned when isRandom is true. It is mutable and never returned. For more information about the use of the IRK, see Volume 1, Part A, Section 5.4.5 of [BLE54].

**mobility:** A boolean attribute to enable BLE device mobility. If set to true, the device could be expected to move within a network of Access Points (APs). For example, if a BLE device is connected with AP-1 and moves out of range but comes in range of AP-2, it will be disconnected with AP-1 and connected with AP-2. It is returned by default and mutable.

### 7.1.2. Multivalued Attributes

**versionSupport:** A multivalued set of strings that specifies the BLE versions supported by the device in the form of an array, for example, ["4.1", "4.2", "5.0", "5.1", "5.2", "5.3", "5.4"]. It is required, mutable, and returned by default.

**pairingMethods:** A multivalued set of strings that specifies pairing methods associated with the BLE device. The pairing methods may require subattributes such as key/password for the device pairing process. To enable the scalability of pairing methods in the future, they are represented as extensions to incorporate various attributes that are part of the respective pairing process. Pairing method extensions are nested inside the BLE extension. It is required, case sensitive, mutable, and returned by default.

### 7.1.3. BLE Pairing Method Extensions

The details on pairing methods and their associated attributes are in Volume 1, Part A, Section 5.2.4 of [BLE54]. This memo defines extensions for four pairing methods that are nested inside the BLE extension schema. Each extension contains the common attributes in Section 6.1. These extensions are as follows:

pairingNull extension: Identified using the following schema URI:

```
urn:ietf:params:scim:schemas:extension:pairingNull:2.0:Device
```

pairingNull does not have any attribute. It allows pairing for BLE devices that do not require a pairing method.

pairingJustWorks extension: Identified using the following schema URI:

```
urn:ietf:params:scim:schemas:extension:pairingJustWorks:2.0:Device
```

The Just Works pairing method does not require a key to pair devices. For completeness, the key attribute is included and is set to 'null'. The key attribute is required, immutable, and returned by default.

pairingPassKey extension: Identified using the following schema URI:

```
urn:ietf:params:scim:schemas:extension:pairingPassKey:2.0:Device
```

The passkey pairing method requires a 6-digit key to pair devices. This extension has one singular integer attribute, "key", which is required, mutable, and returned by default. The key pattern is as follows:

```
^[0-9]{6}$
```

pairingOOB extension: Identified using the following schema URI:

```
urn:ietf:params:scim:schemas:extension:pairingOOB:2.0:Device
```

The out-of-band (OOB) pairing method includes three singular attributes: key, randomNumber, and confirmationNumber.

key:

A string value that is required and received from out-of-band sources such as Near Field Communication (NFC). It is case sensitive, mutable, and returned by default.

**randomNumber:**

An integer that represents a nonce added to the key. It is a required attribute. It is mutable and returned by default.

**confirmationNumber:**

An integer that some solutions require in a RESTful message exchange (where RESTful refers to the Representational State Transfer (REST) architecture). It is not required. It is mutable and returned by default if it exists.

Attribute	Multi Value	Req	Case Exact	Mutable	Return	Unique
deviceMacAddress	F	T	F	RW	Def	Manuf
isRandom	F	T	F	RW	Def	None
sepBroadcastAdd	T	F	F	RW	Def	None
irk	F	F	F	WO	Nev	Manuf
versionSupport	T	T	F	RW	Def	None
mobility	F	F	F	RW	Def	None
pairingMethods	T	T	T	RW	Def	None

*Table 3: Characteristics of BLE Extension Schema Attributes*

Legend: sepBroadcastAdd = separateBroadcastAddress, Req = Required, T = True, F = False, RW = ReadWrite, WO = WriteOnly, Def = Default, Nev = Never, Manuf = Manufacturer

Example:

```

<CODE BEGINS>
{
  "schemas": ["urn:ietf:params:scim:schemas:core:2.0:Device",
    "urn:ietf:params:scim:schemas:extension:ble:2.0:Device"],

  "id": "e9e30dba-f08f-4109-8486-d5c6a3316111",
  "displayName": "BLE Heart Monitor",
  "active": true,
  "urn:ietf:params:scim:schemas:extension:ble:2.0:Device" : {
    "versionSupport": ["5.4"],
    "deviceMacAddress": "2C:54:91:88:C9:E2",
    "isRandom": false,
    "separateBroadcastAddress": ["AA:BB:88:77:22:11", "AA:BB:88:77:\
      22:12"],

    "mobility": true,
    "pairingMethods": ["urn:ietf:params:scim:schemas:extension:\
      pairingPassKey:2.0:Device"],
    "urn:ietf:params:scim:schemas:extension:pairingPassKey:2.0:\
      Device" : {
      "key": 123456
    }
  },
  "meta": {
    "resourceType": "Device",
    "created": "2022-01-23T04:56:22Z",
    "lastModified": "2022-05-13T04:42:34Z",
    "version": "W\/\\"a330bc54f0671c9\"",
    "location": "https://example.com/v2/Devices/e9e30dba-f08f-4109-\
      8486-d5c6a3316111"
  }
}
<CODE ENDS>

```

*Figure 5: BLE Example*

In the above example, the pairing method is "pairingPassKey", which implies that this BLE device pairs using only a passkey. In another example below, the pairing method is "pairingOOB", denoting that this BLE device uses the out-of-band pairing method.

Example:

```

<CODE BEGINS>
{
  "schemas": ["urn:ietf:params:scim:schemas:core:2.0:Device",
    "urn:ietf:params:scim:schemas:extension:ble:2.0:Device"],

  "id": "e9e30dba-f08f-4109-8486-d5c6a3316111",
  "displayName": "BLE Heart Monitor",
  "active": true,
  "urn:ietf:params:scim:schemas:extension:ble:2.0:Device" : {
    "versionSupport": ["5.4"],
    "deviceMacAddress": "2C:54:91:88:C9:E2",
    "isRandom": false,
    "separateBroadcastAddress": ["AA:BB:88:77:22:11", "AA:BB:88:77:\
      22:12"],

    "mobility": true,
    "pairingMethods": ["urn:ietf:params:scim:schemas:extension:\
      pairingOOB:2.0:Device"],

    "urn:ietf:params:scim:schemas:extension:pairingOOB:2.0:Device": {
      "key": "TheKeyvalueRetrievedFromOOB",
      "randomNumber": 238796813516896
    }
  },
  "meta": {
    "resourceType": "Device",
    "created": "2022-01-23T04:56:22Z",
    "lastModified": "2022-05-13T04:42:34Z",
    "version": "W\/\\"a330bc54f0671c9\"",
    "location": "https://example.com/v2/Devices/e9e30dba-f08f-4109-\
      8486-d5c6a3316111"
  }
}
<CODE ENDS>

```

Figure 6: BLE with pairingOOB

However, a device can have more than one pairing method. Support for multiple pairing methods is also provided by the multivalued attribute pairingMethods. In the example below, the BLE device can pair with both passkey and OOB pairing methods.

Example:

```

<CODE BEGINS>
{
  "schemas": ["urn:ietf:params:scim:schemas:core:2.0:Device",
    "urn:ietf:params:scim:schemas:extension:ble:2.0:Device"],

  "id": "e9e30dba-f08f-4109-8486-d5c6a3316111",
  "displayName": "BLE Heart Monitor",
  "active": true,
  "urn:ietf:params:scim:schemas:extension:ble:2.0:Device" : {
    "versionSupport": ["5.4"],
    "deviceMacAddress": "2C:54:91:88:C9:E2",
    "isRandom": false,
    "separateBroadcastAddress": ["AA:BB:88:77:22:11", "AA:BB:88:77:\
      22:12"],

    "mobility": true,
    "pairingMethods": ["urn:ietf:params:scim:schemas:extension:\
      pairingPassKey:2.0:Device",
      "urn:ietf:params:scim:schemas:extension:pairing00B:2.0:\
      Device"],
    "urn:ietf:params:scim:schemas:extension:pairingPassKey:2.0:\
      Device" : {
      "key": 123456
    },
    "urn:ietf:params:scim:schemas:extension:pairing00B:2.0:Device": {
      "key": "TheKeyvalueRetrievedFrom00B",
      "randomNumber": 238796813516896
    }
  },
  "meta": {
    "resourceType": "Device",
    "created": "2022-01-23T04:56:22Z",
    "lastModified": "2022-05-13T04:42:34Z",
    "version": "W\/\\"a330bc54f0671c9\"",
    "location": "https://example.com/v2/Devices/e9e30dba-f08f-4109-\
      8486-d5c6a3316111"
  }
}
<CODE ENDS>

```

Figure 7: BLE Pairing with Both Passkey and OOB

## 7.2. Wi-Fi Easy Connect Extension

This section describes a schema that extends the device schema to enable Wi-Fi Easy Connect (otherwise known as Device Provisioning Protocol (DPP)). Throughout this specification, we use the term "DPP". The extension is identified using the following schema URI:

urn:ietf:params:scim:schemas:extension:dpp:2.0:Device

The attributes in this extension are adopted from [DPP2]. The attributes are as follows.

### 7.2.1. Singular Attributes

**dppVersion:** An integer that represents the version of DPP the device supports. This attribute is required, case insensitive, mutable, and returned by default.

**bootstrapKey:** A string value representing an Elliptic Curve Diffie-Hellman (ECDH) public key. The base64-encoded lengths for P-256, P-384, and P-521 are 80, 96, and 120 characters. This attribute is required, case sensitive, mutable, and returned by default.

**deviceMacAddress:** A MAC address stored as a string. It is a unique 48-bit value. This attribute is optional, case insensitive, mutable, and returned by default. Its form is identical to that of the deviceMacAddress for BLE devices.

**serialNumber:** An alphanumeric serial number stored as a string. It may also be passed as bootstrapping information. This attribute is optional, case insensitive, mutable, and returned by default.

### 7.2.2. Multivalued Attributes

**bootstrappingMethod:** One or more strings of all the bootstrapping methods available on the enrollee device, for example, [QR, NFC]. This attribute is optional, case insensitive, mutable, and returned by default.

**classChannel:** One or more strings representing the global operating class and channel shared as bootstrapping information. It is formatted as class/channel, for example, ['81/1','115/36']. This attribute is optional, case insensitive, mutable, and returned by default.

Attribute	Multi Value	Req	Case Exact	Mutable	Return	Unique
dppVersion	F	T	F	RW	Def	None
bootstrapKey	F	T	T	WO	Nev	None
deviceMacAddress	F	F	F	RW	Def	Manuf
serialNumber	F	F	F	RW	Def	None
bootstrappingMethod	T	F	F	RW	Def	None
classChannel	T	F	F	RW	Def	None

*Table 4: Characteristics of DPP Extension Schema Attributes*

Legend: Req = Required, T = True, F = False, RW = ReadWrite, WO = WriteOnly, Def = Default, Nev = Never, Manuf = Manufacturer

Example:

```

<CODE BEGINS>
{
  "schemas": [ "urn:ietf:params:scim:schemas:core:2.0:Device",
               "urn:ietf:params:scim:schemas:extension:dpp:2.0:\
               Device" ],

  "id": "e9e30dba-f08f-4109-8486-d5c6a3316111",
  "displayName": "WiFi Heart Monitor",
  "active": true,
  "urn:ietf:params:scim:schemas:extension:dpp:2.0:Device" : {
    "dppVersion": 2,
    "bootstrappingMethod": [ "QR" ],
    "bootstrapKey": "\
MDkwEwYHkoZIZj0CAQYIKoZIZj0DAQcDIgADURzxmttZoIRIPWGoQMV00XHWCAQIhXru\
VWOz0NjlkIA=",
    "deviceMacAddress": "2C:54:91:88:C9:F2",
    "classChannel": [ "81/1", "115/36" ],
    "serialNumber": "4774LH2b4044"
  },

  "meta": {
    "resourceType": "Device",
    "created": "2022-01-23T04:56:22Z",
    "lastModified": "2022-05-13T04:42:34Z",
    "version": "W\/\\"a330bc54f0671c9\"",
    "location": "https://example.com/v2/Devices/e9e30dba-f08f-\
4109-8486-d5c6a3316111"
  }
}
<CODE ENDS>

```

Figure 8: DPP Example

### 7.3. Ethernet MAB Extension

This extension enables a legacy means of (very) weak authentication, known as MAC Authenticated Bypass (MAB), that is supported in many wired ethernet solutions. If the MAC address is known, then the device may be permitted (perhaps limited) access. The extension is identified by the following URI:

urn:ietf:params:scim:schemas:extension:ethernet-mab:2.0:Device

Note that this method is not likely to work properly with MAC address randomization.

#### 7.3.1. Single Attribute

This extension has a singular attribute:

**deviceMacAddress:** This is the Ethernet address to be provisioned onto the network. It takes the identical form as found in the BLE extension.

Attribute	Multi Value	Req	Case Exact	Mutable	Return	Unique
deviceMacAddress	F	T	F	RW	Def	None

Table 5: Characteristics of MAB Extension Schema Attributes

Legend: Req = Required, T = True, F = False, RW = ReadWrite, Def = Default

Example:

```
<CODE BEGINS>
{
  "schemas": ["urn:ietf:params:scim:schemas:core:2.0:Device",
             "urn:ietf:params:scim:schemas:extension:ethernet-mab:2.0:Device"],
  "id": "e9e30dba-f08f-4109-8486-d5c6a3316111",
  "displayName": "Some random Ethernet Device",
  "active": true,
  "urn:ietf:params:scim:schemas:extension:ethernet-mab:2.0:Device" \
    : {
    "deviceMacAddress": "2C:54:91:88:C9:E2"
  },
  "meta": {
    "resourceType": "Device",
    "created": "2022-01-23T04:56:22Z",
    "lastModified": "2022-05-13T04:42:34Z",
    "version": "W\\"a330bc54f0671c9\"",
    "location": "https://example.com/v2/Devices/e9e30dba-f08f-4109-\
                8486-d5c6a3316111"
  }
}
<CODE ENDS>
```

Figure 9: MAB Example

## 7.4. FIDO Device Onboard Extension

This extension specifies a voucher to be used by the FIDO Device Onboard (FDO) protocols [FDO11] to complete a trusted transfer of ownership and control of the device to the environment. The SCIM server **MUST** know how to process the voucher, either directly or by forwarding it along to an owner process as defined in the FDO specification. The extension is identified using the following schema URI:

urn:ietf:params:scim:schemas:extension:fido-device-onboard:2.0:Device

### 7.4.1. Single Attribute

This extension has a singular attribute:

fdoVoucher: The voucher is formatted as a PEM-encoded object in accordance with [FDO11].

Attribute	Multi Value	Req	Case Exact	Mutable	Return	Unique
fdoVoucher	F	T	F	WO	Nev	None

Table 6: Characteristics of FDO Extension Schema Attributes

Legend: Req = Required, T = True, F = False, WO = WriteOnly, Nev = Never

Example:

```
<CODE BEGINS>
{
  "schemas": ["urn:ietf:params:scim:schemas:core:2.0:Devices",
             "urn:ietf:params:scim:schemas:extension:fido-device-onboard:2.0\
             :Devices"],

  "id": "e9e30dba-f08f-4109-8486-d5c6a3316111",
  "displayName": "Some random Ethernet Device",
  "active": true,
  "urn:ietf:params:scim:schemas:extension:fido-device-onboard:2.0:\
  Devices" : {
    "fdoVoucher": "{... voucher ...}"
  },

  "meta": {
    "resourceType": "Device",
    "created": "2022-01-23T04:56:22Z",
    "lastModified": "2022-05-13T04:42:34Z",
    "version": "W\/\\"a330bc54f0671c9\"",
    "location": "https://example.com/v2/Devices/e9e30dba-f08f-4109-\
    8486-d5c6a3316111"
  }
}
<CODE ENDS>
```

Figure 10: FDO Example

## 7.5. Zigbee Extension

This section describes a schema that extends the device schema to enable the provisioning of Zigbee devices [Zigbee]. The extension is identified using the following schema URI:

urn:ietf:params:scim:schemas:extension:zigbee:2.0:Device

It has one singular attribute and one multivalued attribute. The attributes are as follows.

### 7.5.1. Singular Attribute

deviceEui64Address:

A 64-bit Extended Unique Identifier (EUI-64) device address stored as string. This attribute is required, case insensitive, mutable, and returned by default. It takes the same form as the deviceMACaddress in the BLE extension.

### 7.5.2. Multivalued Attribute

versionSupport: One or more strings of all the Zigbee versions supported by the device, for example, [3.0]. This attribute is required, case insensitive, mutable, and returned by default.

Attribute	Multi Value	Req	Case Exact	Mutable	Return	Unique
deviceEui64Address	F	T	F	RW	Def	None
versionSupport	T	T	F	RW	Def	None

Table 7: Characteristics of Zigbee Extension Schema Attributes

Legend: Req = Required, T = True, F = False, RW = ReadWrite, Def = Default

Example:

```
<CODE BEGINS>
{
  "schemas": ["urn:ietf:params:scim:schemas:core:2.0:Device",
    "urn:ietf:params:scim:schemas:extension:zigbee:2.0:Device"],

  "id": "e9e30dba-f08f-4109-8486-d5c6a3316111",
  "displayName": "Zigbee Heart Monitor",
  "active": true,
  "urn:ietf:params:scim:schemas:extension:zigbee:2.0:Device" : {
    "versionSupport": ["3.0"],
    "deviceEui64Address": "50:32:5F:FF:FE:E7:67:28"
  },

  "meta": {
    "resourceType": "Device",
    "created": "2022-01-23T04:56:22Z",
    "lastModified": "2022-05-13T04:42:34Z",
    "version": "W\\\\"a330bc54f0671c9\\\"",
    "location": "https://example.com/v2/Devices/e9e30dba-f08f-4109-\
      8486-d5c6a3316111"
  }
}
<CODE ENDS>
```

Figure 11: Zigbee Example

## 7.6. The Endpoint Applications Extension Schema

Sometimes non-IP devices such as those using BLE or Zigbee require an application gateway interface to manage them.

endpointAppsExt provides the list of applications that connect to an enterprise gateway. endpointAppsExt has one multivalued attribute and two singular attributes. The extension is identified using the following schema URI:

urn:ietf:params:scim:schemas:extension:endpointAppsExt:2.0:Device

### 7.6.1. Singular Attributes

**deviceControlEnterpriseEndpoint:** A string representing the URL of the enterprise endpoint to reach the enterprise gateway. When the enterprise receives the SCIM object from the onboarding application, it adds this attribute to it and sends it back as a response to the onboarding application. This attribute is required, case sensitive, mutable, and returned by default. The uniqueness is enforced by the enterprise.

**telemetryEnterpriseEndpoint:** A string representing a URL of the enterprise endpoint to reach an enterprise gateway for telemetry. When the enterprise receives the SCIM object from the onboarding application, it adds this attribute to it and sends it back as a response to the onboarding application. This attribute is optional, case sensitive, mutable, and returned by default. The uniqueness is enforced by the enterprise. This attribute is populated when the enterprise provides a telemetry endpoint (e.g., hosted by the enterprise gateway). If a telemetry service is not known by the SCIM server, the attribute will not be returned. In such cases, if the application requires telemetry, separate arrangements must be made.

### 7.6.2. Multivalued Attribute

**applications:** A multivalued attribute of one or more complex attributes that represent a list of endpoint applications, i.e., deviceControl and telemetry. Each entry in the list comprises two attributes including "value" and "\$ref".

**value:** A string containing the identifier of the endpoint application formatted as a Universally Unique Identifier (UUID). It is the same as the common attribute "\$id" of the resource EndpointApp. It is read/write, required, case insensitive, and returned by default.

**\$ref:** A reference to the respective EndpointApp resource object stored in the SCIM server. It is readOnly, required, case sensitive, and returned by default.

Attribute	Multi Value	Req	Case Exact	Mutable	Return	Unique
devContEntEndpoint	F	T	T	R	Def	Ent
telEntEndpoint	F	F	T	R	Def	Ent
applications	T	T	F	RW	Def	None
value	F	T	F	RW	Def	None

Attribute	Multi Value	Req	Case Exact	Mutable	Return	Unique
\$ref	F	T	F	R	Def	None

*Table 8: Characteristics of endpointAppsExt Extension Schema Attributes*

Legend: devContEntEndpoint = deviceControlEnterpriseEndpoint,  
telEntEndpoint = telemetryEnterpriseEndpoint, Req = Required, T = True, F = False,  
RO = ReadOnly, RW = ReadWrite, Ent = Enterprise, Def = Default

Example:

```

<CODE BEGINS>
{
  "schemas": ["urn:ietf:params:scim:schemas:core:2.0:Device",
    "urn:ietf:params:scim:schemas:extension:ble:2.0:Device",
    "urn:ietf:params:scim:schemas:extension:endpointAppsExt:2.0:\
      Device"],
  "id": "e9e30dba-f08f-4109-8486-d5c6a3316111",
  "displayName": "BLE Heart Monitor",
  "active": true,
  "urn:ietf:params:scim:schemas:extension:ble:2.0:Device" : {
    "versionSupport": ["5.4"],
    "deviceMacAddress": "2C:54:91:88:C9:E2",
    "isRandom": false,
    "separateBroadcastAddress": ["AA:BB:88:77:22:11", "AA:BB:88:77:\
      22:12"],
    "mobility": false,
    "pairingMethods": [
      "urn:ietf:params:scim:schemas:extension:pairingPassKey:2.0:\
        Device"],
      "urn:ietf:params:scim:schemas:extension:pairingPassKey:2.0:\
        Device" : {
        "key": 123456
      }
    ],
  },
  "urn:ietf:params:scim:schemas:extension:endpointAppsExt:2.0:Device\
    ": {
    "applications": [
      {
        "value" : "e9e30dba-f08f-4109-8486-d5c6a3316212",
        "$ref" : "https://example.com/v2/EndpointApps/e9e30dba-f08f-\
          4109-8486-d5c6a3316212"
      },
      {
        "value" : "e9e30dba-f08f-4109-8486-d5c6a3316333",
        "$ref" : "https://example.com/v2/EndpointApps/e9e30dba-f08f-\
          4109-8486-d5c6a3316333"
      }
    ],
    "deviceControlEnterpriseEndpoint": "https://example.com/\
      device_control_app_endpoint/",
    "telemetryEnterpriseEndpoint": "mqtt://example.com/\
      telemetry_app_endpoint/"
  },
  "meta": {
    "resourceType": "Device",
    "created": "2022-01-23T04:56:22Z",
    "lastModified": "2022-05-13T04:42:34Z",
    "version": "W\/\\"a330bc54f0671c9\"",
    "location": "https://example.com/v2/Devices/e9e30dba-f08f-4109-\
      8486-d5c6a3316111"
  }
}
<CODE ENDS>

```

Figure 12: Endpoint Applications Extension Example

The schema for the endpointAppsExt extension along with BLE extension is presented in JSON format in [Appendix A.9](#), while the OpenAPI representation is provided in [Appendix B.8](#).

## 8. Security Considerations

Because provisioning operations permit device access to a network, each SCIM client **MUST** be appropriately authenticated.

### 8.1. SCIM Operations

An attacker that has authenticated to a trusted SCIM client could manipulate portions of the SCIM database. To be clear on the risks, we specify each operation below.

#### 8.1.1. Unauthorized Object Creation

An attacker that is authenticated could attempt to add elements that the enterprise would not normally permit on a network. For instance, an enterprise may not wish specific devices that have well-known vulnerabilities to be introduced to their environment. To mitigate the attack, network administrators should layer additional policies regarding what devices are permitted on the network.

An attacker that gains access to SCIM could attempt to add an IP-based device that itself attempts unauthorized access, effectively acting as a bot. Network administrators **SHOULD** establish appropriate access-control policies that follow the principle of least privilege to mitigate this attack.

### 8.2. Object Deletion

Once granted, even if the object is removed, the server may or may not act on that removal. The deletion of the object is a signal of intent by the application that it no longer expects the device to be on the network. It is strictly up to the SCIM server and its back end policy to decide whether or not to revoke access to the infrastructure. It is **RECOMMENDED** that SCIM delete operations trigger a workflow in accordance with local network policy.

### 8.3. Read Operations

Read operations are necessary in order for an application to sync its state to know what devices it is expected to manage. An attacker with access to SCIM objects may gain access to the devices themselves. To prevent one SCIM client from interfering with devices that it has no business managing, only clients that have created objects or those they authorize **SHOULD** have the ability to read those objects.

### 8.4. Update Operations

Update operations may be necessary if a device has been modified in some way. Attackers with update access may be able to disable network access to devices or device access to networks. To avoid this, the same access control policy for read operations is **RECOMMENDED** here.

## 8.5. Higher Level Protection for Certain Systems

Devices provisioned with this model may be completely controlled by the administrator of the SCIM server, depending on how those systems are defined. For instance, if BLE passkeys are provided, the device can be connected to, and perhaps paired with. If the administrator of the SCIM client does not wish the network to have complete access to the device, the device itself **MUST** support finer levels of access control and additional authentication mechanisms. Any additional security must be provided at higher application layers. For example, if client applications wish to keep private information to and from the device, they should encrypt that information over-the-top.

## 8.6. Logging

An attacker could learn what devices are on a network by examining SCIM logs. Due to the sensitive nature of SCIM operations, logs **SHOULD** be encrypted both on the disk and in transit.

# 9. IANA Considerations

## 9.1. New Schemas

IANA has added the following additions to the "SCIM Schema URIs for Data Resources" registry:

Schema URI: urn:ietf:params:scim:schemas:core:2.0:Device

Name: Core Device Schema

Reference: RFC 9944, [Section 3](#)

Schema URI: urn:ietf:params:scim:schemas:core:2.0:EndpointApp

Name: Endpoint Application

Reference: RFC 9944, [Section 6](#)

## 9.2. Device Schema Extensions

IANA has created the following extensions in the "SCIM Server-Related Schema URIs" registry (omitting the "Resource Type" field) as described in [Section 7](#):

Schema URI: urn:ietf:params:scim:schemas:extension:ble:2.0:Device

Name: BLE Extension

Resource Type: Device

Reference: RFC 9944, [Section 7.1](#)

Schema URI: urn:ietf:params:scim:schemas:extension:ethernet-mab:2.0:Device

Name: Ethernet MAB

Resource Type: Device

Reference: RFC 9944, [Section 7.3](#)

Schema URI: urn:ietf:params:scim:schemas:extension:fido-device-onboard:2.0:Device  
Name: FIDO Device Onboard  
Resource Type: Device  
Reference: RFC 9944, [Section 7.4](#)

Schema URI: urn:ietf:params:scim:schemas:extension:dpp:2.0:Device  
Name: Wi-Fi Easy Connect  
Resource Type: Device  
Reference: RFC 9944, [Section 7.2](#)

Schema URI: urn:ietf:params:scim:schemas:extension:endpointAppsExt:2.0:Device  
Name: Application Endpoint Extension  
Resource Type: Device  
Reference: RFC 9944, [Section 7.1.3](#)

Schema URI: urn:ietf:params:scim:schemas:extension:pairingJustWorks:2.0:Device  
Name: Just Works Auth BLE  
Resource Type: Device  
Reference: RFC 9944, [Section 7.1.3](#)

Schema URI: urn:ietf:params:scim:schemas:extension:pairingOOB:2.0:Device  
Name: Out-of-Band Pairing for BLE  
Resource Type: Device  
Reference: RFC 9944, [Section 7.1.3](#)

Schema URI: urn:ietf:params:scim:schemas:extension:pairingPassKey:2.0:Device  
Name: Passkey Pairing for BLE  
Resource Type: Device  
Reference: RFC 9944, [Section 7.1.3](#)

## 10. References

### 10.1. Normative References

- [BLE54] Bluetooth SIG, "Bluetooth Core Specification", Version 5.4, 2023, <[https://www.bluetooth.org/DocMan/handlers/DownloadDoc.ashx?doc\\_id=587177](https://www.bluetooth.org/DocMan/handlers/DownloadDoc.ashx?doc_id=587177)>.
- [DPP2] Wi-Fi Alliance, "Wi-Fi Easy Connect Specification", Version 3.0, 2020, <[https://www.wi-fi.org/system/files/Wi-Fi\\_Easy\\_Connect\\_Specification\\_v3.0.pdf](https://www.wi-fi.org/system/files/Wi-Fi_Easy_Connect_Specification_v3.0.pdf)>.

- 
- [ECMA]** ECMA International, "ECMAScript(R) 2025 Language Specification", ECMA-262, 16th Edition, June 2025, <<https://ecma-international.org/publications-and-standards/standards/ecma-262/>>.
- [FDO11]** FIDO Alliance, "FIDO Device Onboard Specification 1.1", Proposed Standard, April 2022, <<https://fidoalliance.org/specs/FDO/FIDO-Device-Onboard-PS-v1.1-20220419/FIDO-Device-Onboard-PS-v1.1-20220419.html>>.
- [RFC2119]** Bradner, S., "Key words for use in RFCs to Indicate Requirement Levels", BCP 14, RFC 2119, DOI 10.17487/RFC2119, March 1997, <<https://www.rfc-editor.org/info/rfc2119>>.
- [RFC4648]** Josefsson, S., "The Base16, Base32, and Base64 Data Encodings", RFC 4648, DOI 10.17487/RFC4648, October 2006, <<https://www.rfc-editor.org/info/rfc4648>>.
- [RFC5280]** Cooper, D., Santesson, S., Farrell, S., Boeyen, S., Housley, R., and W. Polk, "Internet X.509 Public Key Infrastructure Certificate and Certificate Revocation List (CRL) Profile", RFC 5280, DOI 10.17487/RFC5280, May 2008, <<https://www.rfc-editor.org/info/rfc5280>>.
- [RFC7643]** Hunt, P., Ed., Grizzle, K., Wahlstroem, E., and C. Mortimore, "System for Cross-domain Identity Management: Core Schema", RFC 7643, DOI 10.17487/RFC7643, September 2015, <<https://www.rfc-editor.org/info/rfc7643>>.
- [RFC7644]** Hunt, P., Ed., Grizzle, K., Ansari, M., Wahlstroem, E., and C. Mortimore, "System for Cross-domain Identity Management: Protocol", RFC 7644, DOI 10.17487/RFC7644, September 2015, <<https://www.rfc-editor.org/info/rfc7644>>.
- [RFC8174]** Leiba, B., "Ambiguity of Uppercase vs Lowercase in RFC 2119 Key Words", BCP 14, RFC 8174, DOI 10.17487/RFC8174, May 2017, <<https://www.rfc-editor.org/info/rfc8174>>.
- [RFC8520]** Lear, E., Droms, R., and D. Romascanu, "Manufacturer Usage Description Specification", RFC 8520, DOI 10.17487/RFC8520, March 2019, <<https://www.rfc-editor.org/info/rfc8520>>.
- [Zigbee]** Zigbee Alliance, "Zigbee Specification", ZigBee Document 05-3474-21, August 2015, <<https://zigbeealliance.org/wp-content/uploads/2019/11/docs-05-3474-21-0csg-zigbee-specification.pdf>>.

## 10.2. Informative References

- [JSONSchema]** Wright, A., Ed., Andrews, H. A., Ed., Hutton, B., Ed., and G. Dennis, "JSON Schema: A Media Type for Describing JSON Documents", December 2022, <<https://json-schema.org/draft/2020-12/json-schema-core>>.
- [NIPC]** Brinckman, B., Mohan, R., and B. Sanford, "An Application Layer Interface for Non-Internet-Connected Physical Components (NIPC)", Work in Progress, Internet-Draft, draft-ietf-asdf-nipc-18, 24 February 2026, <<https://datatracker.ietf.org/doc/html/draft-ietf-asdf-nipc-18>>.

- [OAUTHv2]** Hardt, D., Ed., "The OAuth 2.0 Authorization Framework", RFC 6749, DOI 10.17487/RFC6749, October 2012, <<https://www.rfc-editor.org/info/rfc6749>>.
- [OpenAPI]** Swagger, "OpenAPI Specification", Version 3.1.1, October 2024, <<https://swagger.io/specification/>>.
- [RFC6241]** Enns, R., Ed., Bjorklund, M., Ed., Schoenwaelder, J., Ed., and A. Bierman, Ed., "Network Configuration Protocol (NETCONF)", RFC 6241, DOI 10.17487/RFC6241, June 2011, <<https://www.rfc-editor.org/info/rfc6241>>.
- [RFC7950]** Bjorklund, M., Ed., "The YANG 1.1 Data Modeling Language", RFC 7950, DOI 10.17487/RFC7950, August 2016, <<https://www.rfc-editor.org/info/rfc7950>>.
- [RFC8040]** Bierman, A., Bjorklund, M., and K. Watsen, "RESTCONF Protocol", RFC 8040, DOI 10.17487/RFC8040, January 2017, <<https://www.rfc-editor.org/info/rfc8040>>.
- [RFC8792]** Watsen, K., Auerswald, E., Farrel, A., and Q. Wu, "Handling Long Lines in Content of Internet-Drafts and RFCs", RFC 8792, DOI 10.17487/RFC8792, June 2020, <<https://www.rfc-editor.org/info/rfc8792>>.
- [RFC8995]** Pritikin, M., Richardson, M., Eckert, T., Behringer, M., and K. Watsen, "Bootstrapping Remote Secure Key Infrastructure (BRSKI)", RFC 8995, DOI 10.17487/RFC8995, May 2021, <<https://www.rfc-editor.org/info/rfc8995>>.

## Appendix A. JSON Schema Representation

### A.1. Resource Schema

```
<CODE BEGINS>
[
  {
    "schemas": ["urn:ietf:params:scim:schemas:core:2.0:ResourceType"\
    ],
    "id": "Device",
    "name": "Device",
    "endpoint": "/Devices",
    "description": "Device account.",
    "schema": "urn:ietf:params:scim:schemas:core:2.0:Device",
    "meta": {
      "location": "https://example.com/v2/ResourceTypes/Device",
      "resourceType": "ResourceType"
    }
  },
  {
    "schemas": ["urn:ietf:params:scim:schemas:core:2.0:ResourceType"\
    ],
    "id": "EndpointApp",
    "name": "EndpointApp",
    "endpoint": "/EndpointApp",
    "description": "Endpoint application such as device control and \
    telemetry.",
    "schema": "urn:ietf:params:scim:schemas:core:2.0:EndpointApp",
    "meta": {
      "location": "https://example.com/v2/ResourceTypes/EndpointApp",
      "resourceType": "ResourceType"
    }
  }
]
<CODE ENDS>
```

### A.2. Core Device Schema

```
<CODE BEGINS>
{
  "id": "urn:ietf:params:scim:schemas:core:2.0:Device",
  "name": "Device",
  "description": "Entry containing attributes about a device.",
  "attributes" : [
    {
      "name": "displayName",
      "type": "string",
      "description": "Human-readable name of the device, suitable \
      for displaying to end users, for example, 'BLE Heart Monitor' etc.",
      "multiValued": false,
      "required": false,
      "caseExact": false,
    }
  ]
}
```

```

    "mutability": "readWrite",
    "returned": "default",
    "uniqueness": "none"
  },
  {
    "name": "active",
    "type": "boolean",
    "description": "A mutable boolean value indicating the device \
administrative status. If true, the commands (such as connect, \
disconnect, subscribe) that control app sends to the controller for \
the devices will be processed by the controller. If false, any \
command coming from the control app for the device will be \
rejected by the controller.",
    "multiValued": false,
    "required": true,
    "caseExact": false,
    "mutability": "readWrite",
    "returned": "default",
    "uniqueness": "none"
  },
  {
    "name": "mudUrl",
    "type": "reference",
    "description": "A URL to MUD file of the device (RFC 8520).",
    "multiValued": false,
    "required": false,
    "caseExact": true,
    "mutability": "readWrite",
    "returned": "default",
    "uniqueness": "none"
  },
  {
    "name": "groups",
    "type": "complex",
    "multiValued": true,
    "description": "A list of groups to which the device belongs, \
either through direct membership, through nested groups, or \
dynamically calculated.",
    "required": false,
    "subAttributes": [
      {
        "name": "value",
        "type": "string",
        "multiValued": false,
        "description": "The identifier of the device's group.",
        "required": false,
        "caseExact": false,
        "mutability": "readOnly",
        "returned": "default",
        "uniqueness": "none"
      },
      {
        "name": "$ref",
        "type": "reference",
        "referenceTypes": [
          "Group"
        ],
        "multiValued": false,

```

```

        "description": "The URI of the corresponding 'Group' \
                        resource to which the device belongs.",
        "required": false,
        "caseExact": false,
        "mutability": "readOnly",
        "returned": "default",
        "uniqueness": "none"
    },
    {
        "name": "display",
        "type": "string",
        "multiValued": false,
        "description": "A human-readable name, primarily used for \
                        display purposes.  READ-ONLY.",
        "required": false,
        "caseExact": false,
        "mutability": "readOnly",
        "returned": "default",
        "uniqueness": "none"
    },
    {
        "name": "type",
        "type": "string",
        "multiValued": false,
        "description": "A label indicating the attribute's \
                        function, e.g., 'direct' or 'indirect'.",
        "required": false,
        "caseExact": false,
        "canonicalValues": [
            "direct",
            "indirect"
        ],
        "mutability": "readOnly",
        "returned": "default",
        "uniqueness": "none"
    }
],
"mutability": "readOnly",
"returned": "default"
}
},
"meta" : {
    "resourceType" : "Schema",
    "location" :
        "/v2/Schemas/urn:ietf:params:scim:schemas:core:2.0:Device"
}
}
<CODE ENDS>

```

### A.3. EndpointApp Schema

```

<CODE BEGINS>
{
    "id": "urn:ietf:params:scim:schemas:core:2.0:EndpointApp",
    "name": "EndpointApp",
    "description": "Endpoint application and their credentials.",

```

```
"attributes" : [
  {
    "name": "applicationType",
    "type": "string",
    "description": "This attribute will only contain two values: \
                    deviceControl or telemetry.",
    "multiValued": false,
    "required": true,
    "caseExact": false,
    "mutability": "readOnly",
    "returned": "default",
    "uniqueness": "none"
  },
  {
    "name": "applicationName",
    "type": "string",
    "description": "Human-readable name of the application.",
    "multiValued": false,
    "required": true,
    "caseExact": false,
    "mutability": "readWrite",
    "returned": "default",
    "uniqueness": "none"
  },
  {
    "name": "certificateInfo",
    "type": "complex",
    "description": "Contains X.509 certificate's subject name and \
root CA information associated with the device control or telemetry \
app.",
    "multiValued": false,
    "required": false,
    "caseExact": false,
    "mutability": "readWrite",
    "returned": "default",
    "uniqueness": "none",
    "subAttributes" : [
      {
        "name" : "rootCA",
        "type" : "string",
        "description" : "The base64 encoding of the DER encoding \
                        of the CA certificate.",
        "multiValued" : false,
        "required" : false,
        "caseExact" : true,
        "mutability" : "readWrite",
        "returned" : "default",
        "uniqueness" : "none"
      },
      {
        "name" : "subjectName",
        "type" : "string",
        "description" : "A Common Name (CN) of the form of CN = \
                        dnsName.",
        "multiValued" : false,
        "required" : true,
        "caseExact" : true,
        "mutability" : "readWrite",
```

```

        "returned" : "default",
        "uniqueness" : "none"
    }
  ]
},
{
  "name": "clientToken",
  "type": "string",
  "description": "This attribute contains a token that the \
client will use to authenticate itself. Each token may be a string \
up to 500 characters in length.",
  "multiValued": false,
  "required": false,
  "caseExact": true,
  "mutability": "readOnly",
  "returned": "default",
  "uniqueness": "none"
},
{
  "name": "groups",
  "type": "complex",
  "multiValued": true,
  "description": "A list of groups to which an endpoint \
application belongs, either through direct membership, through \
nested groups, or dynamically calculated.",
  "required": false,
  "subAttributes": [
    {
      "name": "value",
      "type": "string",
      "multiValued": false,
      "description": "The identifier of the endpoint application\
's group.",
      "required": false,
      "caseExact": false,
      "mutability": "readOnly",
      "returned": "default",
      "uniqueness": "none"
    },
    {
      "name": "$ref",
      "type": "reference",
      "referenceTypes": [
        "Group"
      ],
      "multiValued": false,
      "description": "The URI of the corresponding 'Group' \
resource to which the endpoint application belongs.",
      "required": false,
      "caseExact": false,
      "mutability": "readOnly",
      "returned": "default",
      "uniqueness": "none"
    },
    {
      "name": "display",
      "type": "string",
      "multiValued": false,

```

```

        "description": "A human-readable name, primarily used for \
                        display purposes.  READ-ONLY.",
        "required": false,
        "caseExact": false,
        "mutability": "readOnly",
        "returned": "default",
        "uniqueness": "none"
    },
    {
        "name": "type",
        "type": "string",
        "multiValued": false,
        "description": "A label indicating the attribute's \
                        function, e.g., 'direct' or 'indirect'.",
        "required": false,
        "caseExact": false,
        "canonicalValues": [
            "direct",
            "indirect"
        ],
        "mutability": "readOnly",
        "returned": "default",
        "uniqueness": "none"
    }
],
"mutability": "readOnly",
"returned": "default"
}
],
"meta" : {
    "resourceType" : "Schema",
    "location" :
        "/v2/Schemas/urn:ietf:params:scim:schemas:core:2.0:Device"
}
}
<CODE ENDS>

```

#### A.4. BLE Extension Schema

```

<CODE BEGINS>
[
  {
    "id": "urn:ietf:params:scim:schemas:extension:ble:2.0:Device",
    "name": "bleExtension",
    "description": "BLE extension for device account.",
    "attributes" : [
      {
        "name": "versionSupport",
        "type": "string",
        "description": "Provides a list of all the BLE versions \
supported by the device, for example, [4.1, 4.2, 5.0, 5.1, 5.2, 5.4]\
                                                                .",
        "multiValued": true,
        "required": true,
        "caseExact": false,
        "mutability": "readWrite",

```

```

    "returned": "default",
    "uniqueness": "none"
  },
  {
    "name": "deviceMacAddress",
    "type": "string",
    "pattern": "^[0-9A-Fa-f]{2}(:[0-9A-Fa-f]{2}){5}$",
    "description": "A unique public MAC address assigned by the \
                    manufacturer.",
    "multiValued": false,
    "required": true,
    "caseExact": false,
    "mutability": "readWrite",
    "returned": "default",
    "uniqueness": "Manufacturer"
  },
  {
    "name": "isRandom",
    "type": "boolean",
    "description": "The isRandom flag is taken from the BLE \
core specifications 5.4. If true, device is using a random address\
                    . Default value is false.",
    "multiValued": false,
    "required": false,
    "caseExact": false,
    "mutability": "readWrite",
    "returned": "default",
    "uniqueness": "none"
  },
  {
    "name": "separateBroadcastAddress",
    "type": "string",
    "description": "When present, this address is used for \
broadcasts/advertisements. This value MUST NOT be set when an IRK \
                    is provided. Its form is the same as deviceMacAddress.",
    "multiValued": true,
    "required": false,
    "caseExact": false,
    "mutability": "readWrite",
    "returned": "default",
    "uniqueness": "none"
  },
  {
    "name": "irk",
    "type": "string",
    "description": "Identity Resolving Key (IRK), which is \
unique for every device. It is used to resolve a random address. \
                    This value MUST NOT be set when separateBroadcastAddress is set.",
    "multiValued": false,
    "required": false,
    "caseExact": false,
    "mutability": "readWrite",
    "returned": "default",
    "uniqueness": "Manufacturer"
  },
  {
    "name": "mobility",
    "type": "bool",

```

```

        "description": "If set to true, the BLE device will \
automatically connect to the closest AP. For example, if a BLE \
device is connected with AP-1 and moves out of range but comes in \
range of AP-2, it will be disconnected with AP-1 and \
connected with AP-2.",
        "multiValued": false,
        "required": false,
        "caseExact": false,
        "mutability": "readWrite",
        "returned": "default",
        "uniqueness": "none"
    },
    {
        "name": "pairingMethods",
        "type": "string",
        "description": "List of pairing methods associated with the \
BLE device, stored as schema URI.",
        "multiValued": true,
        "required": true,
        "caseExact": true,
        "mutability": "readWrite",
        "returned": "default",
        "uniqueness": "none"
    }
],
"meta" : {
    "resourceType" : "Schema",
    "location" : "/v2/Schemas/urn:ietf:params:scim:schemas:\
extension:ble:2.0:Device"
}
},
{
    "id": "urn:ietf:params:scim:schemas:extension:pairingNull:2.0:\
Device",
    "name": "nullPairing",
    "description": "Null pairing method for BLE. It is included for \
the devices that do not have a pairing method.",
    "meta" : {
        "resourceType" : "Schema",
        "location" : "/v2/Schemas/urn:ietf:params:scim:schemas:\
extension:pairingNull:2.0:Device"
    }
},
{
    "id": "urn:ietf:params:scim:schemas:extension:pairingJustWorks:2\
.0:Device",
    "name": "pairingJustWorks",
    "description": "Just Works pairing method for BLE.",
    "attributes" : [
        {
            "name": "key",
            "type": "integer",
            "description": "Just Works does not have any key value. For \
completeness, it is added with a key value 'null'.",
            "multiValued": false,
            "required": true,
            "caseExact": false,
            "mutability": "immutable",

```

```

    "returned": "default",
    "uniqueness": "none"
  }
],
"meta" : {
  "resourceType" : "Schema",
  "location" : "/v2/Schemas/urn:ietf:params:scim:schemas:\
                extension:pairingJustWorks:2.0:Device"
}
},
{
  "id": "urn:ietf:params:scim:schemas:extension:pairingPassKey:2.0\
        :Device",
  "name": "pairingPassKey",
  "description": "Pass key pairing method for BLE.",
  "attributes" : [
    {
      "name": "key",
      "type": "integer",
      "description": "A six-digit passkey for BLE a device. The \
                    pattern of key is ^[0-9]{6}$.",
      "multiValued": false,
      "required": true,
      "caseExact": false,
      "mutability": "readWrite",
      "returned": "default",
      "uniqueness": "none"
    }
  ],
  "meta" : {
    "resourceType" : "Schema",
    "location" : "/v2/Schemas/urn:ietf:params:scim:schemas:\
                  extension:pairingPassKey:2.0:Device"
  }
},
{
  "id": "urn:ietf:params:scim:schemas:extension:pairing00B:2.0:\
        Device",
  "name": "pairing00B",
  "description": "Passkey pairing method for BLE.",
  "attributes" : [
    {
      "name": "key",
      "type": "string",
      "description": "A key value retrieved from out-of-band \
                    source such as NFC.",
      "multiValued": false,
      "required": true,
      "caseExact": true,
      "mutability": "readWrite",
      "returned": "default",
      "uniqueness": "none"
    },
    {
      "name": "randomNumber",
      "type": "integer",
      "description": "Nonce added to the key.",
      "multiValued": false,

```

```

        "required": true,
        "caseExact": false,
        "mutability": "readWrite",
        "returned": "default",
        "uniqueness": "none"
    },
    {
        "name": "confirmationNumber",
        "type": "integer",
        "description": "Some solutions require confirmation number \
in RESTful message exchange.",
        "multiValued": false,
        "required": false,
        "caseExact": false,
        "mutability": "readWrite",
        "returned": "default",
        "uniqueness": "none"
    }
],
"meta" : {
    "resourceType" : "Schema",
    "location" : "/v2/Schemas/urn:ietf:params:scim:schemas:\
extension:pairing00B:2.0:Device"
}
]
<CODE ENDS>

```

## A.5. DPP Extension Schema

```

<CODE BEGINS>
{
    "id": "urn:ietf:params:scim:schemas:extension:dpp:2.0:Device",
    "name": "dppExtension",
    "description": "Device extension schema for Wi-Fi Easy \
Connect / Device Provisioning Protocol (DPP).",
    "attributes" : [
        {
            "name": "dppVersion",
            "type": "integer",
            "description": "Version of DPP this device supports.",
            "multiValued": false,
            "required": true,
            "caseExact": false,
            "mutability": "readWrite",
            "returned": "default",
            "uniqueness": "none"
        },
        {
            "name": "bootstrappingMethod",
            "type": "string",
            "description": "The list of all the bootstrapping methods \
available on the enrollee device, for example, [QR, NFC].",
            "multiValued": true,
            "required": false,
            "caseExact": false,

```

```

    "mutability": "readWrite",
    "returned": "default",
    "uniqueness": "none"
  },
  {
    "name": "bootstrapKey",
    "type": "string",
    "description": "A base64-encoded Elliptic Curve Diffie-\
      Hellman public key (may be P-256, P-384, or P-521).",
    "multiValued": false,
    "required": true,
    "caseExact": true,
    "mutability": "readWrite",
    "returned": "default",
    "uniqueness": "none"
  },
  {
    "name": "deviceMacAddress",
    "type": "string",
    "pattern": "^[0-9A-Fa-f]{2}(:[0-9A-Fa-f]{2}){5}$",
    "description": "A unique public MAC address assigned by the \
      manufacturer.",
    "multiValued": false,
    "required": false,
    "caseExact": false,
    "mutability": "readWrite",
    "returned": "default",
    "uniqueness": "Manufacturer"
  },
  {
    "name": "classChannel",
    "type": "string",
    "description": "A list of global operating class and \
channel shared as bootstrapping information. It is formatted as \
      class/channel, for example, '81/1', '115/36'.",
    "multiValued": true,
    "required": false,
    "caseExact": false,
    "mutability": "readWrite",
    "returned": "default",
    "uniqueness": "none"
  },
  {
    "name": "serialNumber",
    "type": "string",
    "description": "An alphanumeric serial number that may also \
      be passed as bootstrapping information.",
    "multiValued": false,
    "required": false,
    "caseExact": false,
    "mutability": "readWrite",
    "returned": "default",
    "uniqueness": "none"
  }
],
"meta" : {
  "resourceType" : "Schema",

```

```
        "location" : "/v2/Schemas/urn:ietf:params:scim:schemas:\
                        extension:dpp:2.0:Device"
    }
}
<CODE ENDS>
```

## A.6. Ethernet MAB Extension Schema

```
<CODE BEGINS>
{
  "id": "urn:ietf:params:scim:schemas:extension:ethernet-mab:2.0:\
      Device",
  "name": "ethernetMabExtension",
  "description": "Device extension schema for MAC Authentication \
      Bypass.",
  "attributes" : [
    {
      "name": "deviceMacAddress",
      "type": "string",
      "pattern": "^[0-9A-Fa-f]{2}(:[0-9A-Fa-f]{2}){5}$",
      "description": "A MAC address assigned by the manufacturer.",
      "multiValued": false,
      "required": true,
      "caseExact": false,
      "mutability": "readWrite",
      "returned": "default",
      "uniqueness": "Manufacturer"
    }
  ],
  "meta" : {
    "resourceType" : "Schema",
    "location" : "/v2/Schemas/urn:ietf:params:scim:schemas:extension\
      :ethernet-mab:2.0:Device"
  }
}
<CODE ENDS>
```

## A.7. FDO Extension Schema

```
<CODE BEGINS>
{
  "id": "urn:ietf:params:scim:schemas:extension:fido-device-onboard:\
                                         2.0:Devices",
  "name": "FDOExtension",
  "description": "Device extension schema for FIDO Device Onboard (\
                                                         FDO).",
  "attributes" : [
    {
      "name": "fdoVoucher",
      "type": "string",
      "description": "A voucher as defined in the FIDO \
                                                             specification.",
      "multiValued": false,
      "required": true,
      "caseExact": false,
      "mutability": "readWrite",
      "returned": "default",
      "uniqueness": "Manufacturer"
    }
  ],
  "meta" : {
    "resourceType" : "Schema",
    "location" : "/v2/Schemas/urn:ietf:params:scim:schemas:extension\
                                                         :fido-device-onboard:2.0:Devices"
  }
}
<CODE ENDS>
```

## A.8. Zigbee Extension Schema

```

<CODE BEGINS>
{
  "id": "urn:ietf:params:scim:schemas:extension:zigbee:2.0:Device",
  "name": "zigbeeExtension",
  "description": "Device extension schema for Zigbee.",
  "attributes" : [
    {
      "name": "versionSupport",
      "type": "string",
      "description": "Provides a list of all the Zigbee versions \
        supported by the device, for example, [3.0].",
      "multiValued": true,
      "required": true,
      "caseExact": false,
      "mutability": "readWrite",
      "returned": "default",
      "uniqueness": "none"
    },
    {
      "name": "deviceEui64Address",
      "type": "string",
      "pattern": "^[0-9A-Fa-f]{2}(:[0-9A-Fa-f]{2}){7}$",
      "description": "The 64-bit Extended Unique Identifier \
        (EUI-64) device address.",
      "multiValued": false,
      "required": true,
      "caseExact": false,
      "mutability": "readWrite",
      "returned": "default",
      "uniqueness": "none"
    }
  ],
  "meta" : {
    "resourceType" : "Schema",
    "location" : "/v2/Schemas/urn:ietf:params:scim:schemas:extension\
      :zigbee:2.0:Device"
  }
}
<CODE ENDS>

```

## A.9. endpointAppsExt Extension Schema

```

<CODE BEGINS>
{
  "id": "urn:ietf:params:scim:schemas:extension:endpointAppsExt:2.0:\
    Device",
  "name": "endpointAppsExt",
  "description": "Extension for partner endpoint applications that \
    can onboard, control, and communicate with the device.",
  "attributes" : [
    {

```

```
    "name": "applications",
    "type": "complex",
    "description": "Includes references to two types of \
applications that connect with enterprise, i.e., deviceControl and \
telemetry.",
    "multiValued": true,
    "required": true,
    "caseExact": false,
    "mutability": "readWrite",
    "returned": "default",
    "uniqueness": "none",
    "subAttributes" : [
      {
        "name" : "value",
        "type" : "string",
        "description" : "The identifier of the EndpointApp.",
        "multiValued" : false,
        "required" : true,
        "caseExact" : false,
        "mutability" : "readWrite",
        "returned" : "default",
        "uniqueness" : "none"
      },
      {
        "name" : "$ref",
        "type" : "reference",
        "referenceTypes" : "EndpointApps",
        "description" : "The URI of the corresponding EndpointApp\
resource that will control or obtain data from the device.",
        "multiValued" : false,
        "required" : false,
        "caseExact" : true,
        "mutability" : "readOnly",
        "returned" : "default",
        "uniqueness" : "none"
      }
    ]
  },
  {
    "name": "deviceControlEnterpriseEndpoint",
    "type": "reference",
    "description": "The URL of the enterprise endpoint that \
device control apps use to reach enterprise network gateway.",
    "multiValued": false,
    "required": true,
    "caseExact": true,
    "mutability": "readOnly",
    "returned": "default",
    "uniqueness": "Enterprise"
  },
  {
    "name": "telemetryEnterpriseEndpoint",
    "type": "reference",
    "description": "The URL of the enterprise endpoint that \
telemetry apps use to reach enterprise network gateway.",
    "multiValued": false,
    "required": false,
    "caseExact": true,
```

```
    "mutability": "readOnly",
    "returned": "default",
    "uniqueness": "Enterprise"
  }
],
"meta" : {
  "resourceType" : "Schema",
  "location" : "/v2/Schemas/urn:ietf:params:scim:schemas:extension\
                :endpointAppsExt:2.0:Device"
}
}
}
<CODE ENDS>
```

## Appendix B. OpenAPI Representation

The following sections are provided for informational purposes.

### B.1. Core Device Schema OpenAPI Representation

OpenAPI representation of core device schema is as follows:

```
<CODE BEGINS>
openapi: 3.1.0
info:
  title: SCIM Device Schema
  version: 1.0.0

components:
  schemas:
    Group:
      type: object
      description: A list of groups to which the device belongs,
                  either through direct membership, through nested
                  groups, or dynamically calculated.
      properties:
        value:
          type: string
          description: The unique identifier of a group,
                      typically a UUID.
          readOnly: true
          writeOnly: false
        display:
          type: string
          description: A display string for the group.
          readOnly: true
          writeOnly: false
        $ref:
          type: string
          format: uri
          description: Reference to the group object.
          readOnly: true
          writeOnly: true
    Device:
      description: Entry containing attributes about a device.
```

```
type: object
properties:
  displayName:
    type: string
    description: "Human-readable name of the device, suitable
      for displaying to end users, for example,
      'BLE Heart Monitor' etc."
    readOnly: false
    writeOnly: false
  active:
    type: boolean
    description: A mutable boolean value indicating the device
      administrative status. If true, the
      commands (such as connect, disconnect,
      subscribe) that control app sends to the
      controller for the devices will be processed
      by the controller. If false, any command
      coming from the control app for the device
      will be rejected by the controller.
    readOnly: false
    writeOnly: false
  mudUrl:
    type: string
    format: uri
    description: A URL to MUD file of the device (RFC 8520).
      It is added for future use. Current usage is
      not defined yet.
    readOnly: false
    writeOnly: false
  groups:
    type: array
    description: List of groups to which a device belongs to.
    items:
      $ref: '#/components/schemas/Group'

required:
  - active
additionalProperties: false
allOf:
  - $ref: '#/components/schemas/CommonAttributes'
CommonAttributes:
  type: object
  properties:
    schemas:
      type: array
      items:
        type: string
        enum:
          - urn:ietf:params:scim:schemas:core:2.0:Device
      description: The list of schemas that define the resource.
  id:
    type: string
    format: uri
    description: The unique identifier for a resource.
    readOnly: true
    writeOnly: false
  externalId:
    type: string
```

```
description: An identifier for the resource that is
              defined by the provisioning client.
readOnly: false
writeOnly: false
meta:
  type: object
  readOnly: true
  properties:
    resourceType:
      type: string
      description: The name of the resource type of the
                  resource.
      readOnly: true
      writeOnly: false
    location:
      type: string
      format: uri
      description: The URI of the resource being returned.
      readOnly: true
      writeOnly: false
    created:
      type: string
      format: date-time
      description: The date and time the resource was added
                  to the service provider.
      readOnly: true
      writeOnly: false
    lastModified:
      type: string
      format: date-time
      description: The most recent date and time that the
                  details of this resource were updated at
                  the service provider.
      readOnly: true
      writeOnly: false
    version:
      type: string
      description: The version of the resource.
      readOnly: true
      writeOnly: false
  additionalProperties: false
<CODE ENDS>
```

## B.2. EndpointApp Schema OpenAPI Representation

OpenAPI representation of EndpointApp schema is as follows:

```
<CODE BEGINS>
openapi: 3.1.0
info:
  title: SCIM Endpoint App Schema
  version: 1.0.0

components:
  schemas:
    Group:
```

```
type: object
description: A list of groups to which the endpoint
             application belongs, either through
             direct membership, through nested
             groups, or dynamically calculated.
properties:
  value:
    type: string
    description: The unique identifier of a group,
                 typically a UUID.
    readOnly: true
    writeOnly: false
  display:
    type: string
    description: A display string for the group.
    readOnly: true
    writeOnly: false
  $ref:
    type: string
    format: uri
    description: Reference to the group object.
    readOnly: true
    writeOnly: true
EndpointApp:
  title: EndpointApp
  description: Endpoint application resource.
  type: object
  properties:
    applicationType:
      type: string
      description: This attribute will only contain two values:
                   deviceControl or telemetry.
      readOnly: false
      writeOnly: false

    applicationName:
      type: string
      description: Human-readable name of the application.
      readOnly: false
      writeOnly: false
    groups:
      type: array
      description: List of groups to which the EndpointApp
                   belongs.
      items:
        $ref: '#/components/schemas/Group'

  required:
    - applicationType
    - applicationName

  additionalProperties: true
  oneOf:
    - $ref: '#/components/schemas/clientToken'
    - $ref: '#/components/schemas/certificateInfo'

  allOf:
    - $ref: '#/components/schemas/CommonAttributes'
```

```
clientToken:
  type: string
  description: "This attribute contains a token that the client
    will use to authenticate itself. Each token may
    be a string up to 500 characters in length."
  readOnly: true
  writeOnly: false

certificateInfo:
  type: object
  description: "Contains X.509 certificate's subject name and
    root CA information associated with the device
    control or telemetry app."
  properties:
    rootCA:
      type: string
      description: "The base64 encoding of a trust anchor
        certificate, as per RFC 4648, Section 4."
      readOnly: false
      writeOnly: false

    subjectName:
      type: string
      description: "Also known as the Common Name (CN), the
        Subject Name is a field in the X.509
        certificate that identifies the primary
        domain or IP address for which the
        certificate is issued."
      readOnly: false
      writeOnly: false

  required:
  - subjectName

CommonAttributes:
  type: object
  properties:
    schemas:
      type: array
      items:
        type: string
        enum:
        - urn:ietf:params:scim:schemas:core:2.0:EndpointApp
      description: The list of schemas that define the resource.
    id:
      type: string
      format: uri
      description: The unique identifier for a resource.
      readOnly: true
      writeOnly: false
    meta:
      type: object
      readOnly: true
      properties:
        resourceType:
          type: string
          description: The name of the resource type of the
```

```

        resource.
        readOnly: true
        writeOnly: false
    location:
        type: string
        format: uri
        description: The URI of the resource being returned.
        readOnly: true
        writeOnly: false
    created:
        type: string
        format: date-time
        description: The date and time the resource was added
            to the service provider.
        readOnly: true
        writeOnly: false
    lastModified:
        type: string
        format: date-time
        description: The most recent date and time that the
            details of this resource were updated at
            the service provider.
        readOnly: true
        writeOnly: false
    version:
        type: string
        description: The version of the resource.
        readOnly: true
        writeOnly: false
    additionalProperties: false
<CODE ENDS>

```

### B.3. BLE Extension Schema OpenAPI Representation

OpenAPI representation of BLE extension schema is as follows:

```

<CODE BEGINS>
openapi: 3.1.0
info:
  title: SCIM Bluetooth Extension Schema
  version: 1.0.0

components:
  schemas:
    BleDevice:
      type: object
      description: BLE device schema.
      properties:
        schemas:
          type: array
          items:
            type: string
            enum:
              - urn:ietf:params:scim:schemas:extension:ble:2.0
                :Device
            urn:ietf:params:scim:schemas:extension:ble:2.0:Device:

```

```
    $ref: '#/components/schemas/BleDeviceExtension'
    required: true
BleDeviceExtension:
  type: object
  properties:
    versionSupport:
      type: array
      items:
        type: string
      description: Provides a list of all the BLE versions
                  supported by the device, for example,
                  [4.1, 4.2, 5.0, 5.1, 5.2, 5.4].
      readOnly: false
      writeOnly: false

    deviceMacAddress:
      type: string
      description: It is the public MAC address assigned by the
                  manufacturer. It is a unique 48-bit value. The
                  regex pattern is
                  ^[0-9A-Fa-f]{2}(:[0-9A-Fa-f]{2}){5}.
      readOnly: false
      writeOnly: false

    isRandom:
      type: boolean
      description: AddressType flag is taken from the BLE core
                  specifications 5.4. If false, the device is
                  using a public MAC address. If true, device
                  is using a random address.
      readOnly: false
      writeOnly: false

    separateBroadcastAddress:
      type: string
      description: "When present, this address is used for
                  broadcasts/advertisements. This value
                  MUST NOT be set when an IRK is provided.
                  Its form is the same as deviceMacAddress."
      readOnly: false
      writeOnly: false

    irk:
      type: string
      description: Identity Resolving Key (IRK), which is unique
                  for every device. It is used to resolve a
                  random address.
      readOnly: false
      writeOnly: true

    mobility:
      type: boolean
      description: If set to true, the BLE device will
                  automatically connect to the closest AP. For
                  example, if a BLE device is connected with
                  AP-1 and moves out of range but comes in
                  range of AP-2, it will be disconnected with
                  AP-1 and connected with AP-2.
      readOnly: false
```

```

    writeOnly: false
  pairingMethods:
    type: array
    items:
      type: string
      description: List of pairing methods associated with the
                   BLE device, stored as schema URI.
    readOnly: false
    writeOnly: false
  urn:ietf:params:scim:schemas:extension:pairingNull:2.0
    :Device:
    $ref: '#/components/schemas/NullPairing'
    required: false
  urn:ietf:params:scim:schemas:extension:pairingJustWorks:2.0
    :Device:
    $ref: '#/components/schemas/PairingJustWorks'
    required: false
  urn:ietf:params:scim:schemas:extension:pairingPassKey:2.0
    :Device:
    $ref: '#/components/schemas/PairingPassKey'
    required: false
  urn:ietf:params:scim:schemas:extension:pairingOOB:2.0
    :Device:
    $ref: '#/components/schemas/PairingOOB'
    required: false
  required:
  - versionSupport
  - deviceMacAddress
  - AddressType
  - pairingMethods
  additionalProperties: false

NullPairing:
  type: object

PairingJustWorks:
  type: object
  description: Just Works pairing method for BLE.
  properties:
    key:
      type: integer
      description: Just Works does not have any key value. For
                   completeness, it is added with a key value
                   'null'.
      readOnly: false
      writeOnly: false
  required:
  - key

PairingPassKey:
  type: object
  description: Passkey pairing method for BLE.
  properties:
    key:
      type: integer
      description: A six-digit passkey for a BLE device.
                   The pattern of key is ^[0-9]{6}$.
      readOnly: false

```

```

        writeOnly: true
    required:
    - key

PairingOOB:
  type: object
  description: Out-of-band pairing method for BLE.
  properties:
    key:
      type: string
      description: The OOB key value for a BLE device.
      readOnly: false
      writeOnly: false
    randomNumber:
      type: integer
      description: Nonce added to the key.
      readOnly: false
      writeOnly: true
    confirmationNumber:
      type: integer
      description: Some solutions require a confirmation number
        in the RESTful message exchange.
      readOnly: false
      writeOnly: true
  required:
  - key
  - randomNumber
<CODE ENDS>

```

#### B.4. DPP Extension Schema OpenAPI Representation

OpenAPI representation of DPP extension schema is as follows:

```

<CODE BEGINS>
openapi: 3.1.0
info:
  title: SCIM Device Provisioning Protocol Extension Schema
  version: 1.0.0

components:
  schemas:
    DppDevice:
      type: object
      description: Wi-Fi Easy Connect (DPP) device extension schema.
      properties:
        schemas:
          type: array
          items:
            type: string
            enum:
              - urn:ietf:params:scim:schemas:extension:dpp:2.0
                :Device
            urn:ietf:params:scim:schemas:extension:dpp:2.0:Device:
              $ref: '#/components/schemas/DppDeviceExtension'
              required: true
    DppDeviceExtension:

```

```

type: object
properties:
  dppVersion:
    type: integer
    description: Version of DPP this device supports.
    readOnly: false
    writeOnly: false
  bootstrappingMethod:
    type: array
    items:
      type: string
    description: The list of all the bootstrapping methods
      available on the enrollee device, for
      example, [QR, NFC].
    readOnly: false
    writeOnly: false
  bootstrapKey:
    type: string
    description: An Elliptic Curve Diffie-Hellman
      (ECDH) public key. The base64-encoded length
      for P-256, P-384, and P-521 is 80, 96, and
      120 characters.
    readOnly: false
    writeOnly: true
  deviceMacAddress:
    type: string
    description: The MAC address assigned by the manufacturer.
      The regex pattern is
      ^[0-9A-Fa-f]{2}(:[0-9A-Fa-f]{2}){5}.
    readOnly: false
    writeOnly: false
  classChannel:
    type: array
    items:
      type: string
    description: A list of global operating class and channel
      shared as bootstrapping information. It is
      formatted as class/channel, for example,
      '81/1', '115/36'.
    readOnly: false
    writeOnly: false
  serialNumber:
    type: string
    description: An alphanumeric serial number that may also
      be passed as bootstrapping information.
    readOnly: false
    writeOnly: false
  required:
    - dppVersion
    - bootstrapKey
  additionalProperties: false
<CODE ENDS>

```

## B.5. Ethernet MAB Extension Schema OpenAPI Representation

OpenAPI representation of Ethernet MAB extension schema is as follows:

```
<CODE BEGINS>
openapi: 3.1.0
info:
  title: SCIM MAC Authentication Bypass Extension Schema
  version: 1.0.0

components:
  schemas:
    EthernetMABDevice:
      type: object
      description: Ethernet MAC Authenticated Bypass.
      properties:
        schemas:
          type: array
          items:
            type: string
            enum:
              - urn:ietf:params:scim:schemas:extension:ethernet-mab:2.0:Device
            urn:ietf:params:scim:schemas:extension:ethernet-mab:2.0:Device:
              $ref: '#/components/schemas/EthernetMABDeviceExtension'
              required: true
    EthernetMABDeviceExtension:
      type: object
      properties:
        deviceMacAddress:
          type: string
          description: It is the public MAC address assigned by the manufacturer. It is a unique 48-bit value.
            The regex pattern is
            ^[0-9A-Fa-f]{2}(:[0-9A-Fa-f]{2}){5}.
          readOnly: false
          writeOnly: false
      required:
        - deviceMacAddress
      description: Device extension schema for Ethernet-MAB.
<CODE ENDS>
```

## B.6. FDO Extension Schema OpenAPI Representation

OpenAPI representation of FDO extension schema is as follows:

```
<CODE BEGINS>
openapi: 3.1.0
info:
  title: SCIM FIDO Device Onboarding Extension Schema
  version: 1.0.0

components:
  schemas:
    FIDODevice:
      type: object
      description: FIDO Device Onboarding (FIDO) extension.
      properties:
        schemas:
          type: array
          items:
            type: string
            enum:
              - urn:iETF:params:scim:schemas:extension:fido-device
                -onboard:2.0:Devices
          urn:iETF:params:scim:schemas:extension:fido-device-onboard
            :2.0:Devices:
              $ref: '#/components/schemas/FIDODeviceExtension'
              required: true
    FIDODeviceExtension:
      type: object
      properties:
        fdoVoucher:
          type: string
          description: A FIDO Device Onboard (FIDO) voucher.
          readOnly: false
          writeOnly: false
      required:
        - fdoVoucher
      description: Device extension for a FIDO Device Onboard (FIDO).
<CODE ENDS>
```

## B.7. Zigbee Extension Schema OpenAPI Representation

OpenAPI representation of Zigbee extension schema is as follows:

```

<CODE BEGINS>
openapi: 3.1.0
info:
  title: SCIM Zigbee Extension Schema
  version: 1.0.0

components:
  schemas:
    ZigbeeDevice:
      type: object
      description: Zigbee device schema.
      properties:
        schemas:
          type: array
          items:
            type: string
            enum:
              - urn:ietf:params:scim:schemas:extension:zigbee:2.0:Device
              :Device
          urn:ietf:params:scim:schemas:extension:zigbee:2.0:Device:
            $ref: '#/components/schemas/ZigbeeDeviceExtension'
            required: true
    ZigbeeDeviceExtension:
      type: object
      properties:
        versionSupport:
          type: array
          items:
            type: string
          description: Provides a list of all the Zigbee versions
            supported by the device, for example, [3.0].
          readOnly: false
          writeOnly: false
        deviceEui64Address:
          type: string
          description: The 64-bit Extended Unique Identifier (EUI-64)
            device address. The regex pattern is
            ^[0-9A-Fa-f]{16}$.
          readOnly: false
          writeOnly: false
      required:
        - versionSupport
        - deviceEui64Address
      description: Device extension schema for Zigbee.
<CODE ENDS>

```

## B.8. endpointAppsExt Extension Schema OpenAPI Representation

OpenAPI representation of endpointAppsExt extension schema is as follows:

```

<CODE BEGINS>
openapi: 3.1.0
info:
  title: SCIM Endpoint Extension Schema
  version: 1.0.0

```

```
components:
  schemas:
    EndpointAppsExt:
      type: object
      properties:
        applications:
          $ref: '#/components/schemas/applications'

        deviceControlEnterpriseEndpoint:
          type: string
          format: url
          description: The URL of the enterprise endpoint that
            device control apps use to reach an
            enterprise network gateway.
          readOnly: true
          writeOnly: false

        telemetryEnterpriseEndpoint:
          type: string
          format: url
          description: The URL of the enterprise endpoint that
            telemetry apps use to reach an enterprise
            network gateway.
          readOnly: true
          writeOnly: false

      required:
        - applications
        - deviceControlEnterpriseEndpoint

    applications:
      type: array
      items:
        value:
          type: string
          description: The identifier of the EndpointApp.
          readOnly: false
          writeOnly: false
        ref:
          type: string
          format: uri
          description: The URI of the corresponding EndpointApp
            resource that will control or obtain data
            from the device.
          readOnly: true
          writeOnly: false
      required:
        - value
        - ref
<CODE ENDS>
```

## Appendix C. FIDO Device Onboarding Example Flow

The following diagrams are included to demonstrate how FDO can be used. In this first diagram, a device is onboarded not only to the device owner process but also to the AAA server for initial onboarding. The voucher contains a device certificate that is used by the AAA system for authentication.

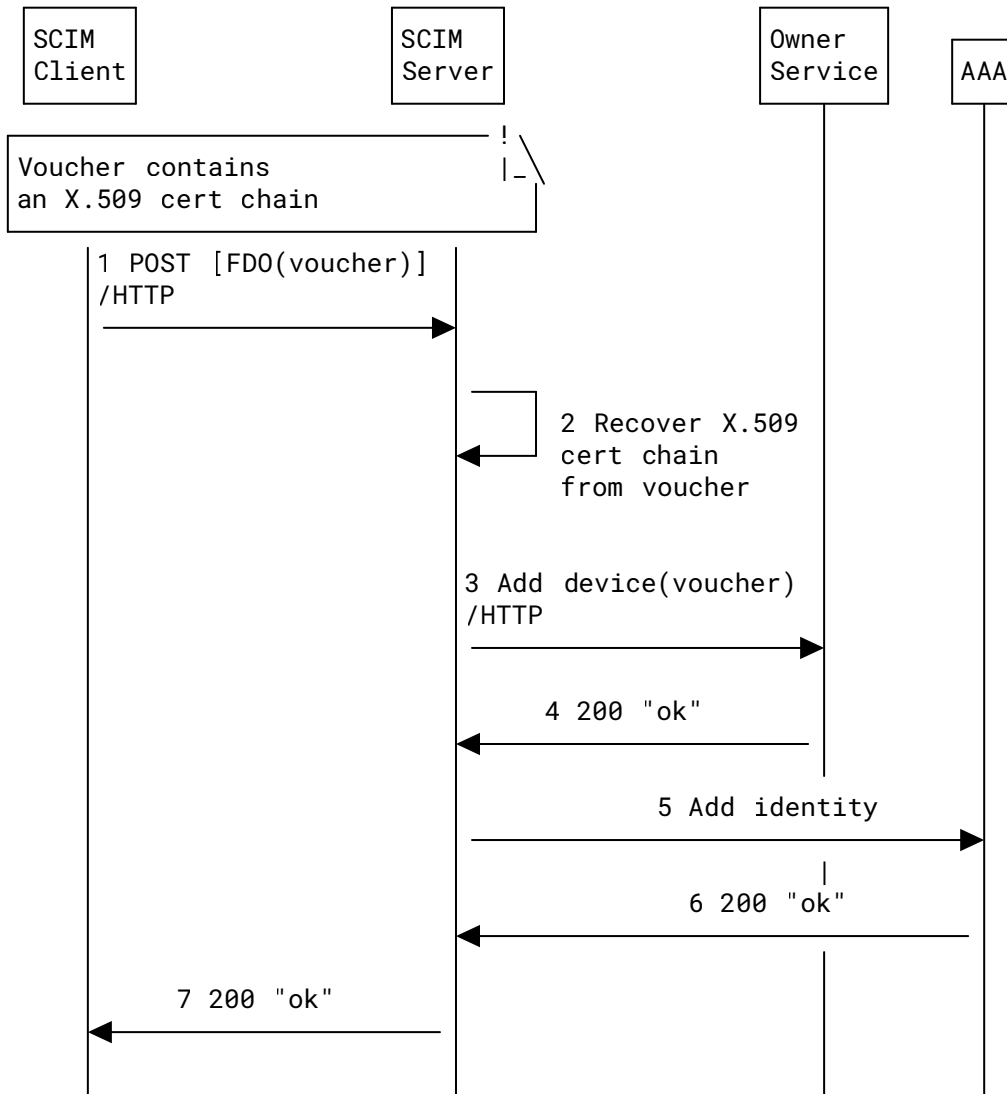

After this flow is complete, the device can then first provisionally onboard and then later receive a trust anchor through FDO's Transfer Ownership Protocol 2 (TO2) process. This is shown below.

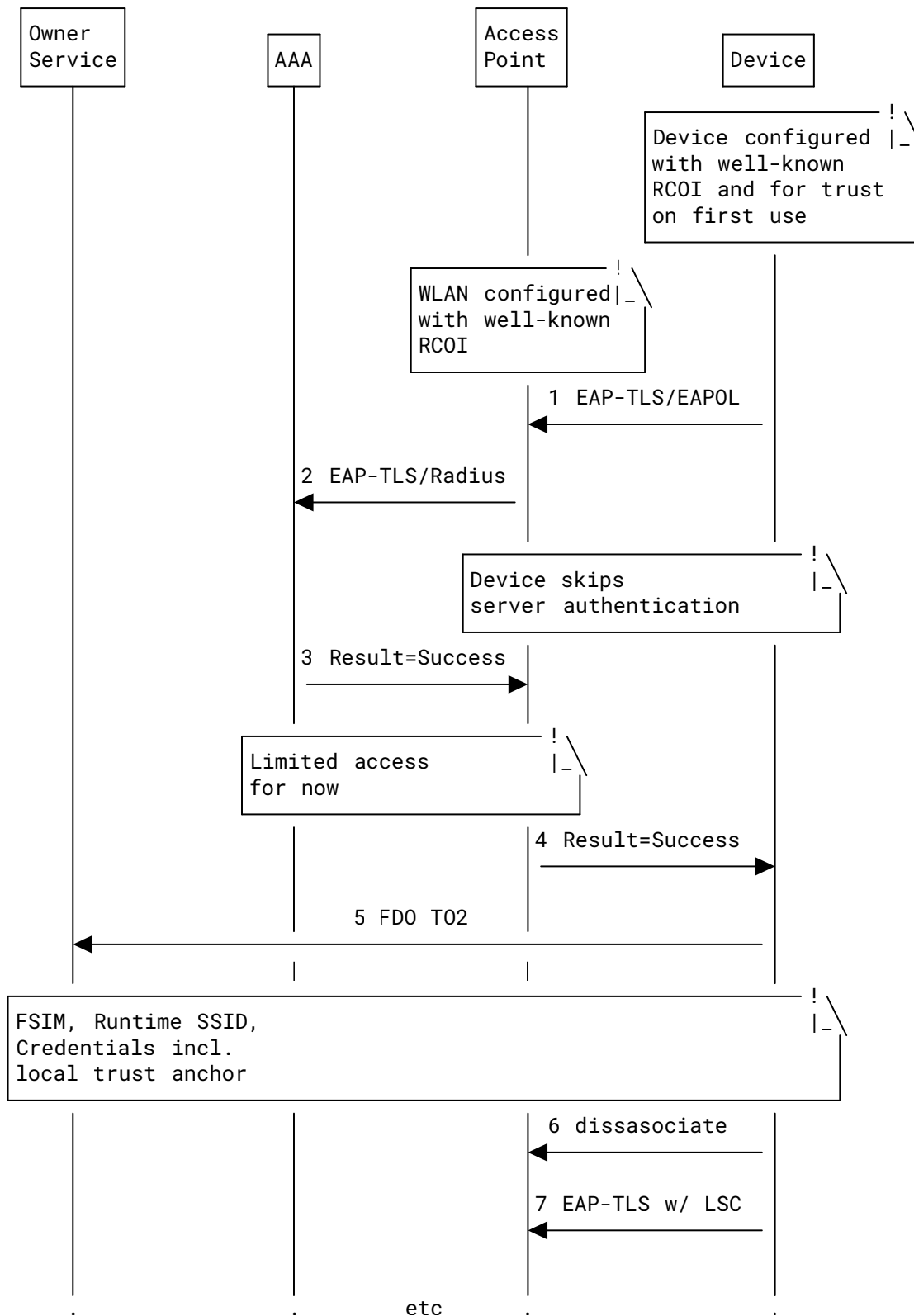

## Acknowledgments

The authors would like to thank Sriram Sekar, Bart Brinckman, Rohit Mohan, Lars Streubesand, Christian Amsüss, Jason Livingwood, Mike Ounsworth, Monty Wiseman, Geoffrey Cooper, Paulo Jorge N. Correia, Phil Hunt, and Elwyn Davies for their reviews and Nick Ross for his contribution to the appendix.

## Authors' Addresses

### Muhammad Shahzad

North Carolina State University  
Department of Computer Science  
890 Oval Drive  
Campus Box 8206  
Raleigh, NC 27695-8206  
United States of America  
Email: [mshahza@ncsu.edu](mailto:mshahza@ncsu.edu)

### Hassan Iqbal

North Carolina State University  
Department of Computer Science  
890 Oval Drive  
Campus Box 8206  
Raleigh, NC 27695-8206  
United States of America  
Email: [hassaniqbal931@gmail.com](mailto:hassaniqbal931@gmail.com)

### Eliot Lear

Cisco Systems  
Richtistrasse 7  
CH-8304 Wallisellen  
Switzerland  
Phone: [+41 44 878 9200](tel:+41448789200)  
Email: [lear@cisco.com](mailto:lear@cisco.com)